

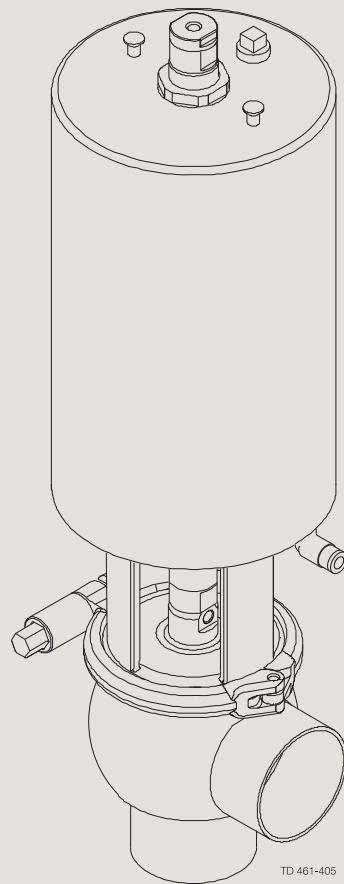

Instruction Manual

Unique Single Seat Valve - Long Stroke

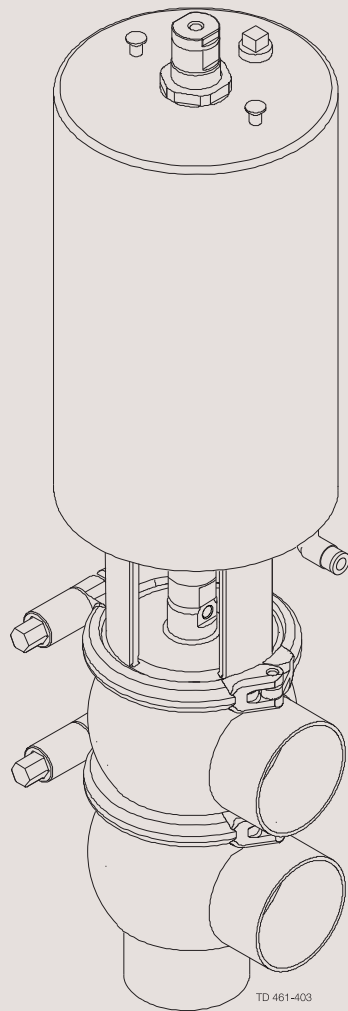

ESE00222-EN6

2016-07

Original manual

The information herein is correct at the time of issue but may be subject to change without prior notice

1. EC Declaration of Conformity	4
2. Safety	5
2.1. Important information	5
2.2. Warning signs	5
2.3. Safety precautions	6
3. Installation	8
3.1. Unpacking/delivery	8
3.2. General installation	9
3.3. Welding	11
3.4. Recycling information	12
4. Operation	13
4.1. Operation	13
4.2. Troubleshooting	15
4.3. Recommended cleaning	16
5. Maintenance	18
5.1. General maintenance	18
5.2. Dismantling the valve	20
5.3. Plug seal replacement	20
5.4. Valve assembly	21
5.5. Actuator bushing replacement (non-maintainable actuator)	21
6. Technical data	22
6.1. Technical data	22
7. Parts list and service kits	23
7.1. Drawing	23
7.2. Unique Single Seat Valve - Long stroke Shut-off Valve	24
7.3. Unique Single Seat Valve - Long Stroke Change-over Valve	26

1 EC Declaration of Conformity

Revision of Declaration of Conformity 2013-12-03

The Designated Company

Alfa Laval Kolding A/S

Company Name

Albuen 31, DK-6000 Kolding, Denmark

Address

+45 79 32 22 00

Phone No.

hereby declare that

Valve

Designation

Unique SSV LS PN10

Type

From serial number 5099880 to 29999999999

is in conformity with the following directive with amendments:

- Machinery Directive 2006/42/EC
- Pressure Equipment Directive 2014/68/EU category 1 and subjected to assessment procedure Module A.

The person authorised to compile the technical file is the signer of this document

Global Product Quality Manager
Pumps, Valves, Fittings and Tank Equipment

Title

Lars Kruse Andersen

Name

Kolding

Place

2016-06-01

Date



Signature



*Unsafe practices and other important information are emphasised in this manual.
Warnings are emphasised by means of special signs.*

2.1 Important information

Always read the manual before using the valve!

WARNING

Indicates that special procedures must be followed to avoid serious personal injury.

CAUTION

Indicates that special procedures must be followed to avoid damage to the valve.

NOTE

Indicates important information to simplify or clarify procedures.

2.2 Warning signs

General warning:



Caustic agents:



2 Safety

All warnings in this manual are summarised on this page.

Pay special attention to this instructions below so that severe personal injury and/or damage to the valve are avoided.

2.3 Safety precautions

Actuators marked with year 2012 (new actuator design):

Alfa Laval recommends not to exceed 3 bar support air on the spring side in all the Unique SSV actuators, to ensure 10 bar product pressure without leakage. Plastic adapter (pos. 5) is always used on the new design.

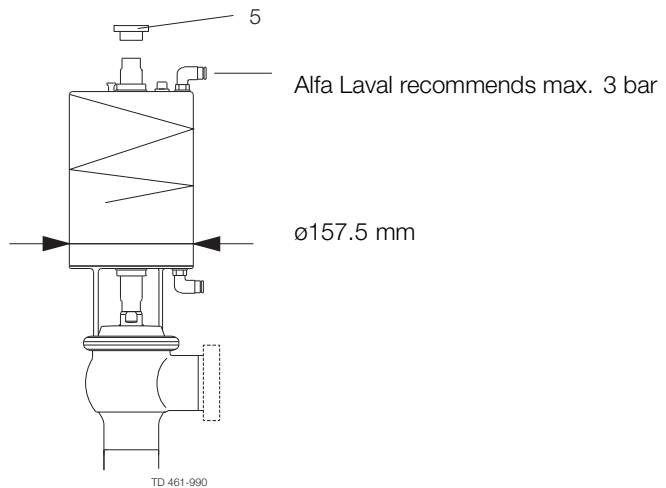

Actuators marked with year 2006-2011 (old actuator design):



WARNING!

When using “support air” on spring side in all the Unique SSV actuators, the pressure must **NOT** exceed 3 bar.

When using Unique SSV actuators with ø156mm with support air, **always** use the “steel adapter” (pos. 5). Tighten the “steel adapter” to a torque of 30 Nm and use Loctite 243.

The actuator with ø156mm is mainly used on valves ISO76/DN80 – ISO101/DN100. The outer actuator diameter = ø156 mm.

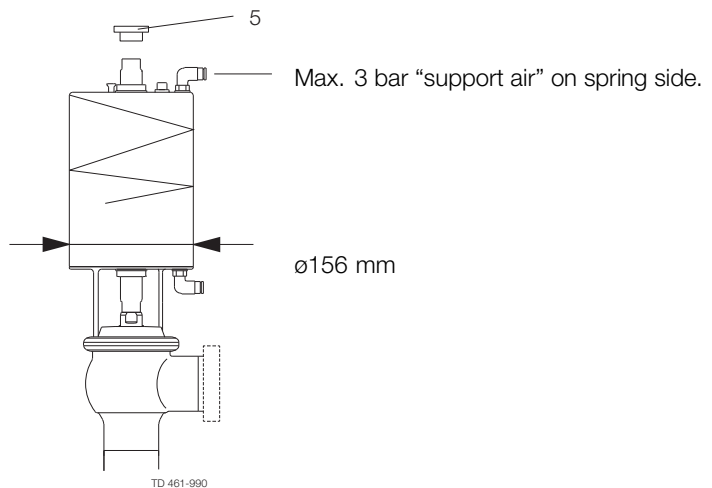

All warnings in this manual are summarised on this page.

Pay special attention to this instructions below so that severe personal injury and/or damage to the valve are avoided.

Installation:

Always read the technical data thoroughly (see chapter 6 Technical data)
Always release compressed air after use
Never touch moving parts if the actuator is supplied with compressed air
Never touch the valve or the pipelines when processing hot liquids or when sterilising
Never dismantle the valve with valve and pipelines under pressure
Never dismantle the valve when it is hot



Operation:

Never dismantle the valve with valve and pipelines under pressure
Never dismantle the valve when it is hot
Always read the technical data thoroughly (see chapter 6 Technical data)
Always release compressed air after use
Never touch the valve or the pipelines when processing hot liquids or when sterilising
Never touch moving parts if the actuator is supplied with compressed air
Always rinse well with clean water after cleaning



Always handle lye and acid with great care



Maintenance:

Always read the technical data thoroughly (see chapter 6 Technical data)
Always release compressed air after use
Never service the valve when it is hot
Never service the valve with valve and pipelines under pressure
Never stick your fingers through the valve ports if the actuator is supplied with compressed air
Never touch moving parts if the actuator is supplied with compressed air



Transportation:

Always ensure that compressed air are released
Always ensure that all connections is disconnected before attempting to remove the valve from the installation
Always drain liquid out of valves before transportation

Always used predesigned lifting points if defined
Always ensure sufficient fixing of the valve during transportation - if specially designed packaging material is available, it must be used

3 Installation

The instruction manual is part of the delivery. Study the instructions carefully.

The items refer to parts list and service kits section.

The valve is supplied as separate parts as standard (for welding).

The valve is assembled before delivery, if it is supplied with fittings.

3.1 Unpacking/delivery

Step 1

CAUTION

Alfa Laval cannot be held responsible for incorrect unpacking.

Check the delivery for:

1. Complete valve, shut-off valve or change-over valve (see steps 2a and 2b).
2. Delivery note.

Step 2

2a

Shut-off valve:

1. Complete actuator.
2. Bonnet (20).
3. Clamp (19).
4. Valve plug (23).
5. Valve body (22).

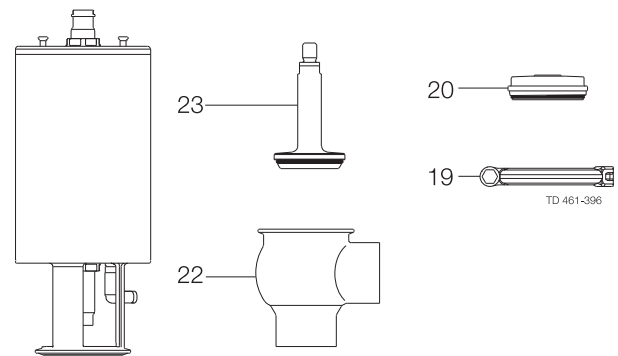

2b

Change-over valve:

1. Complete actuator.
2. Bonnet (20).
3. 2 x clamps (19).
4. Valve plug (27).
5. Lower valve body (22).
6. Valve seat (28).
7. Upper valve body (26).

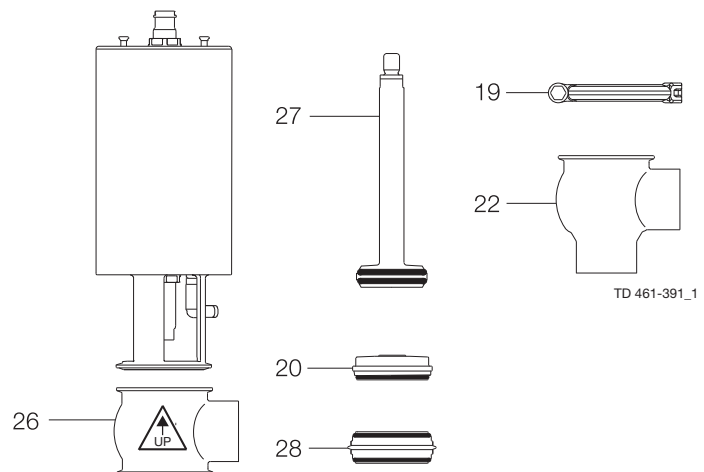

Step 3

Remove possible packing materials from the valve/valve parts.

Inspect the valve/valve parts for visible transport damage.

Avoid damaging the valve/valve parts.

Study the instructions carefully and pay special attention to the warnings!
The valve has welding ends as standard but can also be supplied with fittings.

3.2 General installation

Step 1



Always read the technical data carefully.
See chapter 6 Technical data.



Always release compressed air after use.

CAUTION

Alfa Laval cannot be held responsible for incorrect installation.

Step 2



Never touch the moving parts if the actuator is supplied with compressed air.

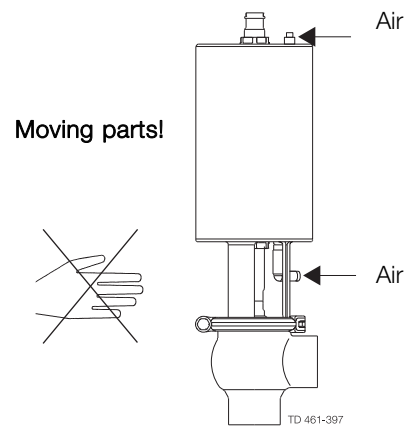

Step 3

It is recommended to install the valve so that the flow is against the closing direction to avoid water hammering.

Shock in the actuator must **never** occur.

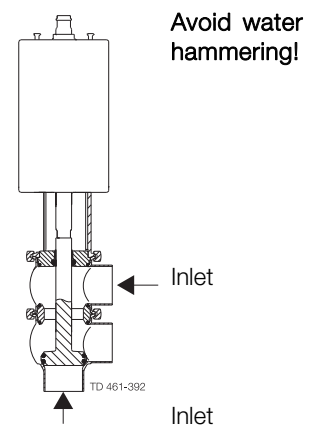

3 Installation

Study the instructions carefully and pay special attention to the warnings!
The valve has welding ends as standard but can also be supplied with fittings.

Step 4

Avoid stressing the valve.

Pay special attention to:

- Vibrations.
- Thermal expansion of the pipelines.
- Excessive welding.
- Overloading of the pipelines.

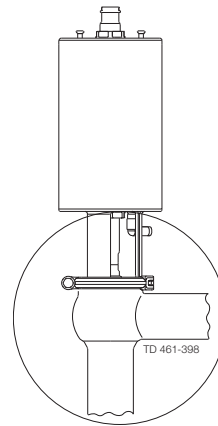

Risk of damage!

Study the instructions carefully.
 The valve is supplied as separate parts to facilitate the welding.
 The items refer to the parts list and service kits section.
 Check the valve for smooth operation after welding.

3.3 Welding

Step 1

Always install valves with more than one valve body so that the seals between the valve bodies can be replaced. Do not weld more than one valve body into the system.

Valve size	A (mm)	B (mm)
DN25/25 mm	*	630
DN40/38 mm	*	700
DN50/51 mm	*	750
DN65/63.5 mm	*	740
DN80/76 mm	*	800
DN100/101.6 mm	*	790

* Depending on body combination and piping solution.

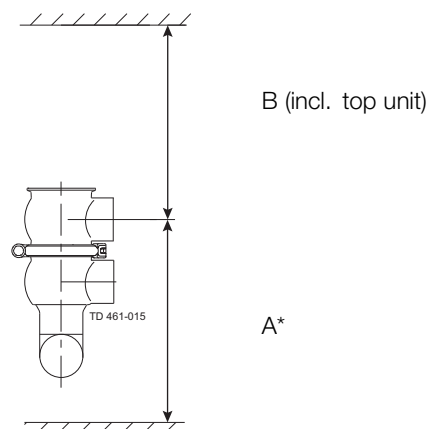

Step 2

Assemble the valve in accordance with the steps on page 21.

Pay special attention to the warnings!

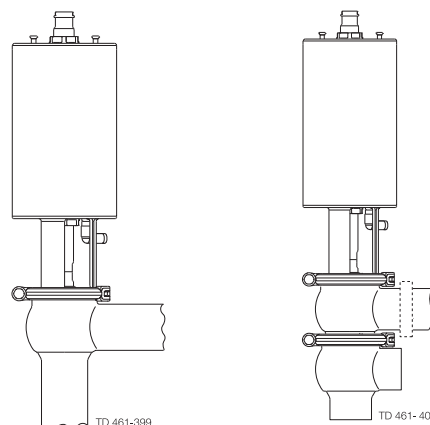

Step 3

Pre-use check:

1. Supply compressed air to the actuator.
2. Open and close the valve several times to ensure that it operates smoothly.

Pay special attention to the warnings!

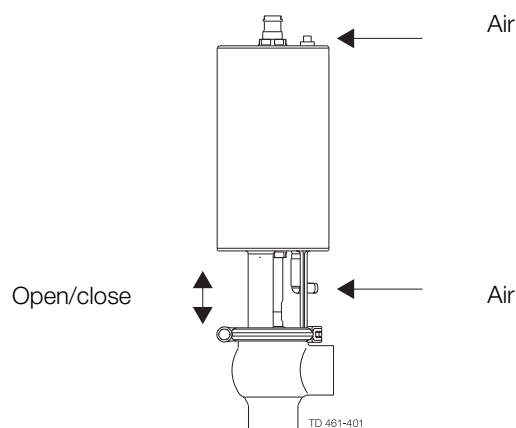

3 Installation

Study the instructions carefully.

The valve is supplied as separate parts to facilitate the welding.

The items refer to the parts list and service kits section.

Check the valve for smooth operation after welding.

3.4 Recycling information

- **Unpacking**

- Packing material consists of wood, plastics, cardboard boxes and in some cases metal straps
- Wood and cardboard boxes can be re-used, recycled or used for energy recovery
- Plastics should be recycled or burnt at a licensed waste incineration plant
- Metal straps should be sent for material recycling.

- **Maintenance**

- During maintenance, oil and wearing parts in the machine are replaced
- All metal parts should be sent for material recycling
- Worn out or defective electronic parts should be sent to a licensed handler for material recycling
- Oil and all non-metal wear parts must be disposed off in agreement with local regulations

- **Scrapping**

- At end of use, the equipment must be recycled according to the relevant, local regulations. Besides the equipment itself, any hazardous residues from the process liquid must be considered and dealt with in a proper manner. When in doubt, or in the absence of local regulations, please contact your local Alfa Laval sales company
-

Study the instructions carefully and pay special attention to the warnings!
 Ensure that the valve operates smoothly.
 The items refer to the parts list and service kits section.

4.1 Operation

Step 1



Always read the technical data carefully.
 See chapter 6 Technical data.



Always release compressed air after use.

CAUTION

Alfa Laval cannot be held responsible for incorrect operation.

Step 2



Never touch the valve or the pipelines when processing hot liquids or when sterilising.

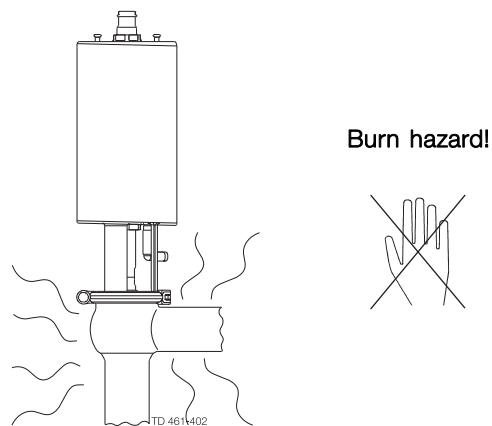

Step 3



Never touch moving parts if the actuator is supplied with compressed air.

Moving parts!

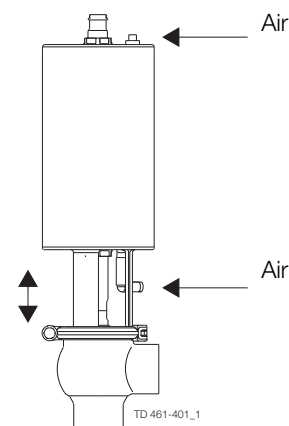

4 Operation

*Study the instructions carefully and pay special attention to the warnings!
Ensure that the valve operates smoothly.
The items refer to the parts list and service kits section.*

Step 4

Lubrication of valves:

1. Ensure smooth movement between lip seal (25) and plug stem (23, 27).
2. Lubricate the lip seal with Klüber Paraliq GTE 703 if necessary (see page 18).

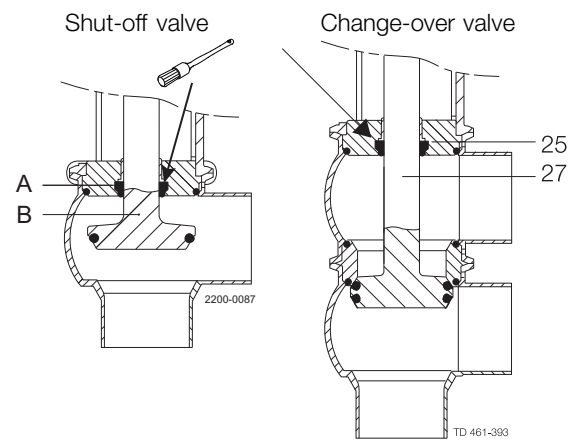

Step 5

Lubrication of actuator

1. Ensure smooth movement of the actuator (the actuator is lubricated before delivery).
2. Lubricate all seals with Molykote Longterm 2 plus if necessary.

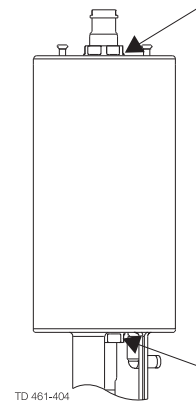

Pay attention to possible faults. Study the instructions carefully.
The items refer to the parts list and service kits section

4.2 Troubleshooting

NOTE!

Study the maintenance instructions carefully before replacing worn parts - see page 18!

Problem	Cause/result	Repair
External product leakage	Worn or product affected lip seal and/or O-ring	<ul style="list-style-type: none"> - Replace the seals - Replace with seals of a different rubber grade
Internal product leakage	<ul style="list-style-type: none"> - Worn or product affected plug seal - Product deposits on the seat and/or plug - Product pressure exceeds actuator specification 	<ul style="list-style-type: none"> - Replace the seal - Replace with a seal of a different rubber grade - Frequent cleaning - Replace with a high pressure actuator - Use auxiliary air on the spring side (do not exceed 3 bar) - Reduce product pressure
Water hammer	The flow direction is the same as the closing direction	<ul style="list-style-type: none"> - The flow direction should be against the closing direction - Throttle air release of solenoid in top unit
The valve does not open/close	Product pressure exceeds actuator specification	<ul style="list-style-type: none"> - Replace with a high pressure actuator - Use auxiliary air on the spring side - Reduce product pressure

4 Operation

The valve is designed for cleaning in place.

Study the instructions carefully and pay special attention to the warnings!

NaOH = Caustic Soda.

HNO₃ = Nitric acid.

4.3 Recommended cleaning

Step 1



Always handle lye and acid with great care.

Caustic danger!



Always use rubber gloves!



Always use protective goggles!

Step 2



Never touch the valve or the pipelines when sterilising.

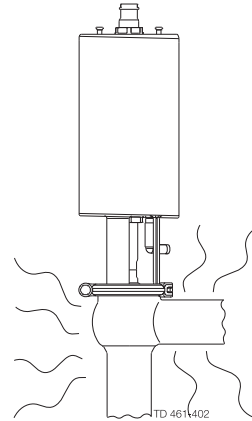

Burn hazard!



Step 3

Clean the plug and the seats correctly.

Pay special attention to the warnings!

Lift and lower valve plug momentarily

Shut-off valve

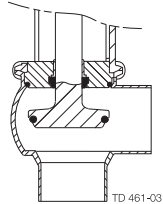

Change-over valve

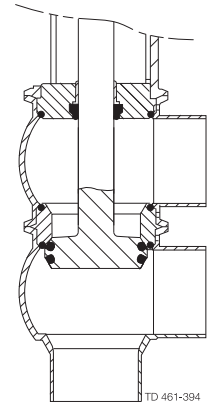

Step 4

Examples of cleaning agents:

Use clean water, free from chlorides.

1. 1% by weight NaOH at 70° C

1 kg NaOH + 100 l water = Cleaning agent.

2.2 l
33% NaOH + 100 l
water = Cleaning agent.

2. 0.5% by weight HNO₃ at 70° C

0.7 l
53% HNO₃ + 100 l
water = Cleaning agent.

The valve is designed for cleaning in place.

Study the instructions carefully and pay special attention to the warnings!

NaOH = Caustic Soda.

HNO₃ = Nitric acid.

Step 5

1. Avoid excessive concentration of the cleaning agent.
2. Adjust the cleaning flow to the process.
3. **Always** rinse well with clean water after the cleaning.

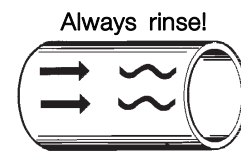

Clean water Cleaning agents

Step 6

NOTE

The cleaning agents must be stored/disposed off in accordance with current regulations/directives.

5 Maintenance

Maintain the valve regularly.

Study the instructions carefully and pay special attention to the warnings!

Always keep spare rubber seals and lip seals in stock.

5.1 General maintenance

Step 1



Always read the technical data carefully.
See chapter 6 Technical data.



Always release compressed air after use.

Step 2



Never service the valve when it is hot.



Never service the valve with valve and pipelines under pressure.

NOTE

All scrap must be stored/discharged in accordance with current rules/directives.

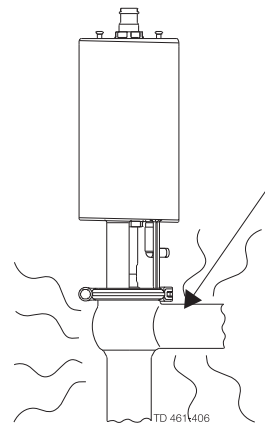

Atmospheric pressure required!

Burn hazard!

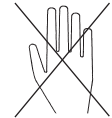

Step 3



Never stick your fingers through the valve ports if the actuator is supplied with compressed air.

Never touch the moving parts if the actuator is supplied with compressed air.

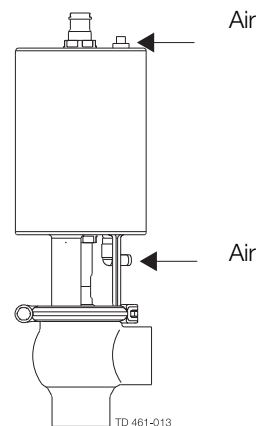

Moving parts!

Cutting hazard!



Maintain the valve regularly.
 Study the instructions carefully and pay special attention to the warnings!
 Always keep spare rubber seals and lip seals in stock.

Below are some guidelines for maintenance and lubrication intervals. Please note that the guidelines are for normal working conditions in one shift.

	Product wetted seals	Actuator bushings complete
Preventive maintenance	Replace after 12 months depending on working conditions	Replace after 5 years depending on working conditions
Maintenance after leakage (leakage normally starts slowly)	Replace at the end of the day	Replace when possible
Planned maintenance	<ul style="list-style-type: none"> - Regular inspection for leakage and smooth operation - Keep a record of the actuator - Use the statistics for inspection planning Replace after leakage	<ul style="list-style-type: none"> - Regular inspection for leakage and smooth operation - Keep a record of the actuator - Use the statistics for inspection planning Replace after leakage
Lubrication	Before fitting Klüber Paraliq GTE 703 or similar USDA H1 approved oil/grease	Before fitting Molykote Longterm 2 plus

Pre-use check:

1. Supply compressed air to the actuator.
 2. Open and close the valve several times to ensure that it operates smoothly.
- Pay special attention to the warnings!**

Open/close!

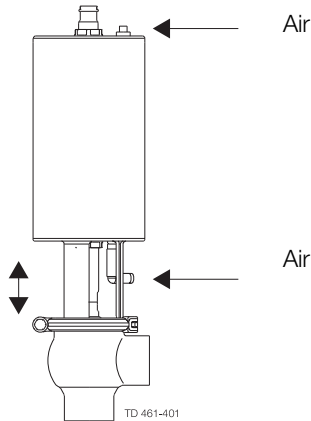

Recommended spare parts
 Service kits (see page 23)

5 Maintenance

Study the instructions carefully. The items refer to the parts list and service kits section. Handle scrap correctly.

NC = Normally closed.

NO = Normally open.

A/A = Air/air activated.

5.2 Dismantling the valve

Step 1

1a

Shut-off valve:

1. Supply compressed air to the actuator (only NC).
2. Loosen and remove clamp.
3. Release compressed air (only NC).
4. Lift away the actuator.
5. Unscrew and remove valve plug.
6. Remove O-ring, lip seal and bushing in bonnet.
(Use bushing tool and rubber mallet).

Note! Be careful not to damage the bushing.

Pay special attention to the warnings!

Note! For plug seal replacement please see page 20.

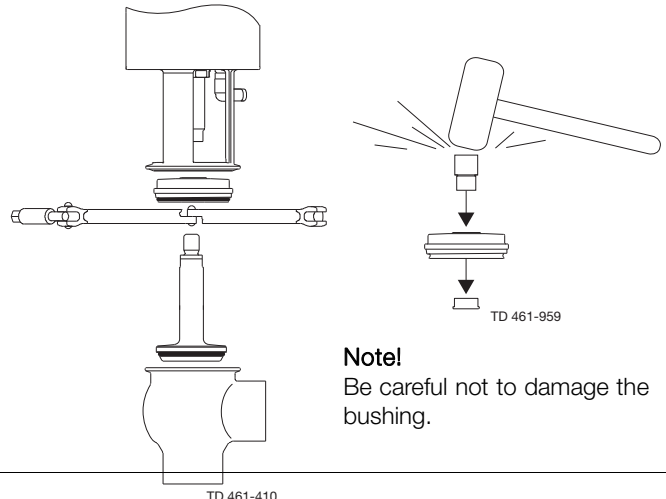

1b

Change-over valve:

1. Supply compressed air to the actuator (only NC).
2. Loosen and remove lower clamp.
3. Release compressed air (only NC).
4. Lift away the actuator and upper valve body.
5. Supply compressed air to the actuator (only NO).
6. Unscrew and remove valve plug.
7. Release compressed air (only NO).
8. Remove seat and O-rings.
9. Loosen and remove upper clamp.
10. Remove upper valve body.
11. Remove O-ring, lip seal and bushing in bonnet.
(Use bushing tool and rubber mallet.
See drawing, step 1a).

Note! Be careful not to damage the bushing.

Pay special attention to the warnings!

Note! For plug seal replacement please see page 20.

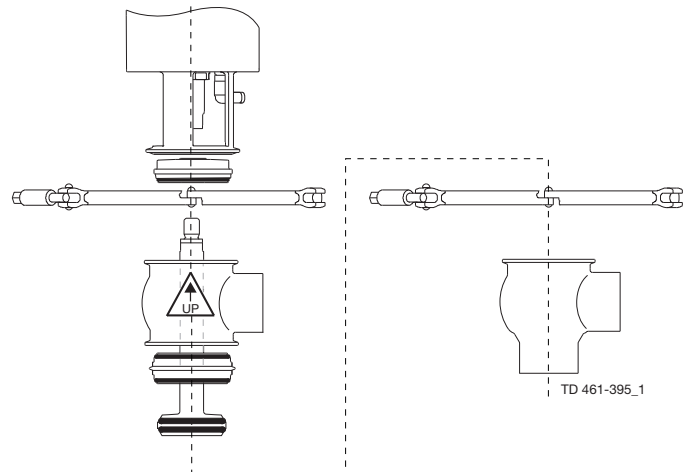

5.3 Plug seal replacement

1. Remove old seal ring using a knife, screwdriver or similar.
Be careful not to damage metal parts.
2. Pre-mount plug seal without pressing it into the groove.
3. Squeeze plug seal into the groove using opposite pressure points.
4. Release compressed air behind plug seal.

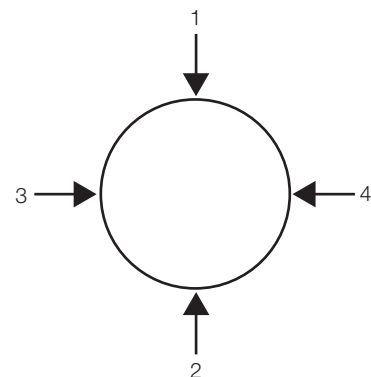

Study the instructions carefully.

The items refer to the parts list and service kits section. Handle scrap correctly.

5.4 Valve assembly

Reverse order of 5.2 Dismantling the valve.

Lubricate O-ring (21) and lip seal (25) with Klüber Paraliq GTE 703.

Remember to tighten spindle and plug to a torque of **30Nm** (to use two 17mm spanners)

If there are vibrations in the pipeline Alfa Laval recommended to using locitite no. 243.

The clamps thread must be lubricated before tightening - max. torque for the clamps is 10-12 Nm.

5.5 Actuator bushing replacement (non-maintainable actuator)

1. Unscrew and remove top and bottom bushings with O-rings.
2. Lubricate O-rings with Molykote Longterm 2 plus before fitting.
3. Fit bushings and O-rings. Tighten bushing to a torque of 10Nm.
Be careful not to overtighten.

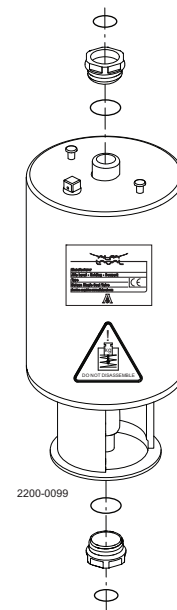

6 Technical data

*It is important to observe the technical data during installation, operation and maintenance.
Inform all personnel about the technical data.*

6.1 Technical data

The valve is a pneumatic seat valve in a hygienic and modular design remote-controlled by means of compressed air.

It has few and simple moveable parts which results in a very reliable valve and low maintenance cost.

Standard Design The valve comes in a one or two body configuration. With its module built structure it is designed for flexibility and easy customization through the electronic configurator.

Data - valve/actuator	
Max. product pressure	1000 kPa (10 bar).
Min. product pressure	Full vacuum (depending on product specifications).
Temperature range	-10° C to + 140° C (standard EPDM seal).
Air pressure, actuator	500 to 700 kPa (5 to 7 bar).
Materials - valve/actuator	
Product wetted steel parts	1.4404 (316L) (internal Ra < 0.8 µm).
Other steel parts	1.4301 (304).
Optional plug seal	PTFE (TR2).
Product wetted seals	EPDM (standard).
Optional product wetted seals	HNBR and FPM.
Other seals	NBR.

Weight (kg)

Size	Inch tubes DN/OD					DIN tubes DN				
	38 mm	51 mm	63.5 mm	76.1 mm	101.6 mm	40	50	65	80	100
Shut-off valve	6.1	6.6	7.5	14.8	17.2	6.2	6.6	7.6	15.3	17.2
Change-over-valve	6.8	7.9	9.8	17.9	22.2	7	7.9	10.1	18.8	22.1

Noise

One metre away from and 1.6 meter above the exhaust the noise level of a valve actuator will be approximately 77db (A) without noise damper and approximately 72 db (A) with damper - measured at 7 bar air-pressure.

7 Parts list and service kits

The drawing shows Unique Single Seat Valve - Long Stroke.
The items refer to the parts list in the following sections

7.1 Drawing

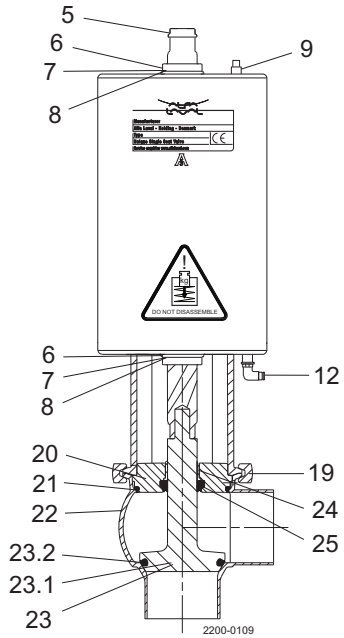

Shut-off valve

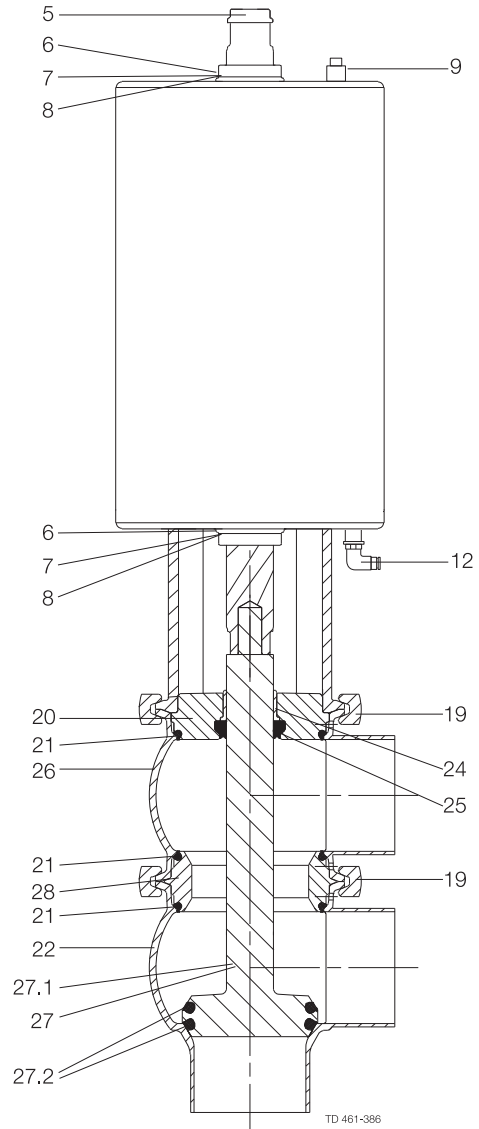

Change-over valve

7 Parts list and service kits

The drawing shows Unique Single Seat Valve - Long Stroke, Shut-off.
The items refer to the parts lists in the following sections.

7.2 Unique Single Seat Valve - Long stroke Shut-off Valve

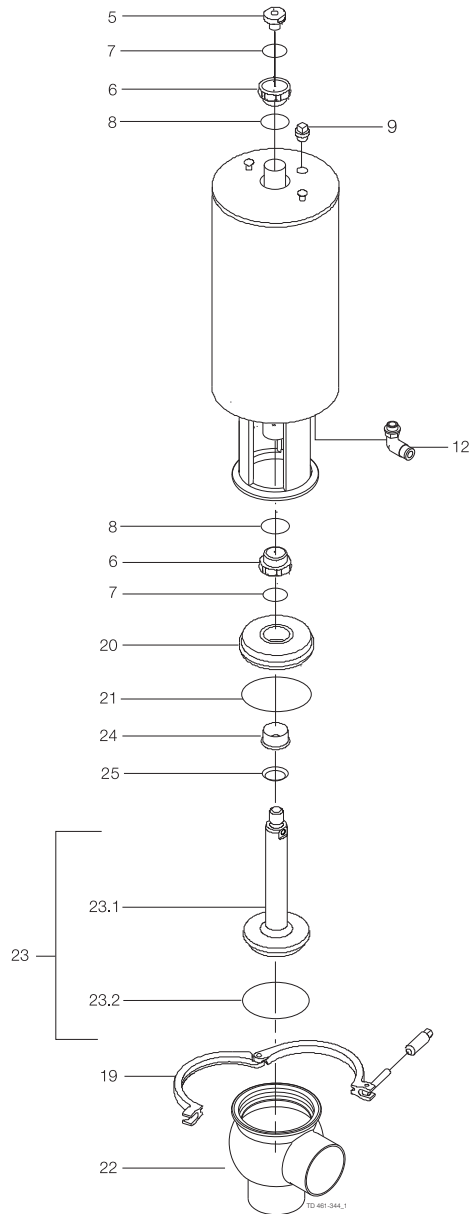

7 Parts list and service kits

The drawing shows Unique Single Seat Valve - Long Stroke, Shut-off.
The items refer to the parts lists in the following sections.

Parts list

Pos.	Qty	Denomination
5	1	Actuator
6 □	2	Adapter
7 □	2	Bushing
8 □	2	O-ring
9	1	O-ring
12	1(2)	Plug
19	1	Air fitting
20	1	Clamp
21 ♦	1	Bonnet
22	1	O-ring
23	1	Valve body
23.1	1	Plug
23.2 ♦	1	Plug, shut-off, ISO/DIN
24	1	Plug seal
25 ♦	1	Bushing
		Lip seal

Service kits

Denomination	DN 40 38 mm	DN 50 51 mm	DN 65 63.5 mm	DN 80 76.1 mm	DN 100 101.6 mm
Service kit for actuator					
□ Service kit	9611926500	9611926500	9611926500	9611926500	9611926500
Service kit for product wetted parts, standard					
♦ Service kit, EPDM	9611926502	9611926503	9611926504	9611926505	9611926506
♦ Service kit, HNBR	9611926508	9611926509	9611926510	9611926511	9611926512
♦ Service kit, FPM	9611926514	9611926515	9611926516	9611926517	9611926518

Parts marked with □♦ are included in the service kits.
Recommended spare parts: Service kits.

TD 900-334/1

7 Parts list and service kits

The drawing shows Unique Single Seat Valve - Long Stroke, Change-over.
The items refer to the parts lists in the following sections.

7.3 Unique Single Seat Valve - Long Stroke Change-over Valve

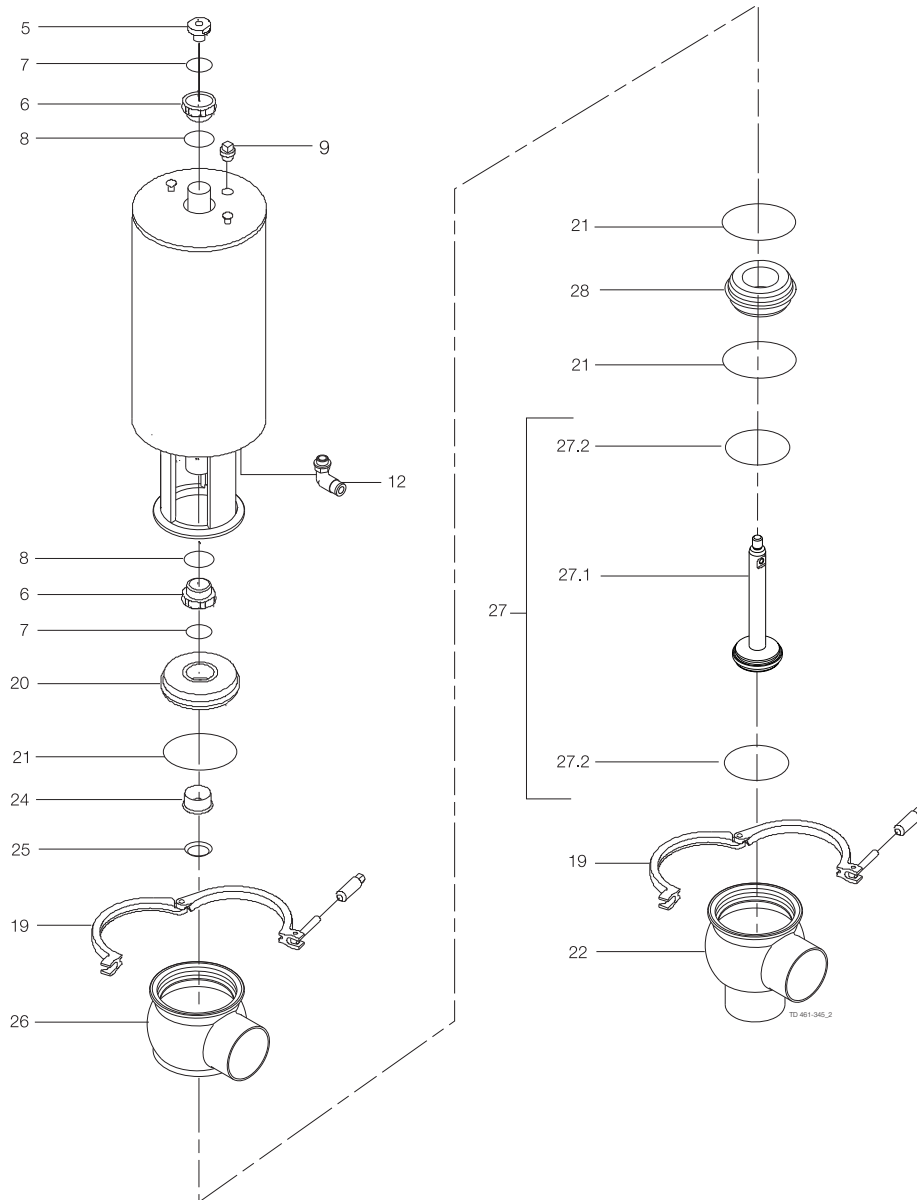

7 Parts list and service kits

The drawing shows Unique Single Seat Valve - Long Stroke, Change-over.
The items refer to the parts lists in the following sections.

Parts list

Pos.	Qty	Denomination
5	1	Actuator
6 □	2	Adapter
7 □	2	Bushing
8 □	2	O-ring
9	1	O-ring
12	1(2)	Plug
19	2	Air fitting
20	1	Clamp
21 ♦	3	Bonnet
22	1	O-ring
24	1	Valve body
25 ♦	1	Bushing
26	1	Lip seal
27	1	Valve body
27.1	1	Plug
27.2 ♦	2	Plug, change-over, ISO/DIN
28	1	Plug seal
		Seat

Service kits

Denomination	DN 40 38 mm	DN 50 51 mm	DN 65 63.5 mm	DN 80 76.1 mm	DN 100 101.6 mm
Service kit for actuator					
□ Service kit	9611926500	9611926500	9611926500	9611926500	9611926500
Service kit for product wetted parts, standard					
♦ Service kit, EPDM	9611926580	9611926581	9611926582	9611926583	9611926584
♦ Service kit, HNBR	9611926586	9611926587	9611926588	9611926589	9611926590
♦ Service kit, FPM	9611926592	9611926593	9611926594	9611926595	9611926596

Parts marked with □♦ are included in the service kits.
Recommended spare parts: Service kits.

TD 900-334/1

How to contact Alfa Laval

Contact details for all countries are continually updated on our website.

Please visit www.alfalaval.com to access the information directly.

© Alfa Laval Corporate AB

This document and its contents is owned by Alfa Laval Corporate AB and protected by laws governing intellectual property and thereto related rights. It is the responsibility of the user of this document to comply with all applicable intellectual property laws. Without limiting any rights related to this document, no part of this document may be copied, reproduced or transmitted in any form or by any means (electronic, mechanical, photocopying, recording, or otherwise), or for any purpose, without the expressed permission of Alfa Laval Corporate AB. Alfa Laval Corporate AB will enforce its rights related to this document to the fullest extent of the law, including the seeking of criminal prosecution.