



Instruction Manual

Alfa Laval Toftejorg™ MultiJet 50



Covering:
Standard Machines
Machines delivered with ATEX/IECEX Certification in accordance with Directive 2014/34/EU
First published: 2010

ESE02851-EN5 2019-07

Original manual

The information herein is correct at the time of issue but may be subject to change without prior notice

1. EC/EU Declaration of Conformity	5
2. Safety	6
2.1. Important information	6
2.2. Warning signs	6
3. Introduction	7
3.1. Introduction	7
3.2. Intended use	7
3.3. Patents and trademarks	7
3.4. Marking	8
3.5. ATEX/IECEX marking	9
3.6. ATEX/IECEX temperature class and code	10
3.7. Quality system	10
4. Installation	11
4.1. General Description	11
4.2. Functioning	11
4.3. General Safety and Installation Instructions	13
4.4. Specific conditions for safe use in accordance with ATEX/IECEX certification	15
5. Operation	18
5.1. Normal operation	18
5.2. Safety precautions	19
6. Maintenance	20
6.1. Service and repair of ATEX/IECEX certified machines	20
6.2. Preventive Maintenance	21
6.3. Top Assembly	22
6.4. Bottom Assembly	24
6.5. Hub Subassembly	26
6.6. Stem Subassembly	28
6.7. Gear Subassembly	30
6.8. Replacement of Collar Bushes	32
6.9. Replacement of Ball Races	34
6.10. Replacement of Main Collars	36
7. Trouble shooting guide	37
8. Technical data	38
8.1. Toftejorg MultiJet 50 with 2 nozzles	38
8.2. Toftejorg MultiJet 50 with 4 nozzles	42
9. Product programme	46
9.1. Standard Configurations	46
9.2. Available add-ons	47
10. Parts list and drawing, service kits and tools	48
10.1. MultiJet 50 with 2 nozzles	48
10.2. MultiJet 50 with 4 nozzles	50
10.3. Service intervals	52
10.4. Tools	53

Table of contents

The information herein is correct at the time of issue but may be subject to change without prior notice

11. General information	55
11.1. Service and repair	55
11.2. How to order spare parts	55
11.3. How to contact Alfa Laval Kolding A/S	55

1 EC/EU Declaration of Conformity

The Designated Company

Alfa Laval Kolding A/S

Company Name

Albuen 31, DK-6000 Kolding, Denmark

Address

+45 79 32 22 00

Phone No.

hereby declare that

Tank Cleaning Machine

Designation

Alfa Laval Toftejorg MultiJet 50

Type

From serial number 2019-0001 to 2030-99999

is in conformity with Machinery Directive 2006/42/EC and the following harmonized standard is used:
DS/EN ISO 12100:2011 Safety of Machinery - Risk Assessment

is in conformity with (Ex / ATEX) Directive 2014/34/EU and the following harmonized standards are used:
EN ISO 80079-36:2016, EN ISO 80079-37:2016, DS/EN ISO/IEC 80079-34:2011, Annex A, paragraph A.5.3 Rotating machines

EC Type Examination Certificate no. Baseefa10ATEX0188X and IECEX BAS 19.0087X

Marking:  II 1G Ex h IIC 85°C... 175°C Ga
II 1D Ex h IIIC T85°C... T140°C Da

*The QAN (Quality Assurance Notification) is carried out by SGS Fimko Oy, Särkiniementie 3, Helsinki 00211, Finland. Notified Body No. 0598.
EU Type Examination Certification is carried out by SGS Fimko Oy, Särkiniementie 3, Helsinki 00211, Finland. Notified Body no. 0598.
IECEX Certificate of Conformity is carried out by Baseefa Ltd., Rockhead Business Park, Staden Lane, Buxton, Derbyshire SK17 9RZ, United Kingdom. IECEX Accepted Certification Body (ExCB).*

The person authorised to compile the technical file is the signer of this document.

Global Product Quality Manager
Pumps, Valves, Fittings and Tank Equipment

Title

Lars Kruse Andersen

Name



Signature

Kolding

Place

2019-07-01

Date (YYYY-MM-DD)

This Declaration of Conformity replaces Declaration of Conformity dated 2015-11-01



2 Safety

Unsafe practices and other important information are emphasized in this manual.

Warnings are emphasized by means of special signs.

Always read the manual before using the tank cleaning machine!

2.1 Important information

WARNING

Indicates that special procedures must be followed to avoid serious personal injury.

CAUTION

Indicates that special procedures must be followed to avoid damage to the tank cleaning machine

NOTE

Indicates important information to simplify or clarify procedures.

2.2 Warning signs

General warning:



ATEX/IECEx warning:



3.1 Introduction

This manual has been prepared as a guide for installing, operating and maintaining your Alfa Laval Toftejorg tank cleaning machine. Should you require further assistance, our Technical Sales Support department and worldwide net of sales offices will be pleased to help you. Please quote the type, article and serial numbers with all of your enquiries; this helps us to help you. The type and serial number are placed on the gear house of the tank cleaning machine.

Get the best and most economical performance from your tank cleaning machine. Insufficient preventive maintenance means poor performance, unscheduled stops, shorter lifetime and extra costs. On the contrary, good preventive maintenance means good performance, no unscheduled stops and superior total economy

Warning:



Before installing the machine and setting it into operation, carefully read the General safety and installation instructions (page 13) and the specific conditions for safe use in accordance with ATEX/IECEX Directive 2014/34/EU (page 15) and take all necessary precautions according to your application and local regulations.

NOTE

The illustrations and specifications contained in this manual were effective at the date of printing. However, as continuous improvements are our policy, we reserve the right to alter or modify any unit specification on any product without prior notice or any obligation.

The English version of the instruction manual is the original manual. We make reservations in regard to possible mistranslations in language versions of the instruction manual. In case of doubt, the English version of the instruction manual applies.

3.2 Intended use

The end-user should verify:

- that the tank cleaning machine is in conformity with respect to tank, vessel or container size in which it is used.
- that the construction materials (both metallic and non-metallic) are compatibility with product, flushing media, cleaning media, temperatures and pressure under the intended use.

The tank cleaning machine is intended for use in closed tank, vessel or container. If used in open environment see 4.3 General Safety and Installation Instructions.

To ensure the self cleanability and drainability the machine must be installed in vertical position.

3.3 Patents and trademarks

This Instruction Manual is published by Alfa Laval without any warranty. Improvements and changes to this Instruction Manual may at any time be made by Alfa Laval without prior notice. Such changes will, however, be incorporated in new editions of this Instruction Manual.

Alfa Laval Kolding A/S. All rights reserved.

The Alfa Laval logotype is a trademark or a registered trademark of Alfa Laval Corporate AB. "Toftejorg" is a trademark or registered trademark of Alfa Laval. Other products or company names mentioned herein may be the trademarks of their respective owners. Any rights not expressly granted herein are reserved.

3 Introduction

3.4 Marking

Alfa Laval tank cleaning machines are all marked to allow for recognition of type of machine, machine name, serial number and manufacturing address. The marking is placed on the gear house of the tank cleaning machine.

Rotary Jet Head
MultiJet 50
s/n.: yyyy-xxxxx
Alfa Laval, DK-6000 Kolding, Albuen 31
CE

Serial number explanation:

Machines supplied with or without standard documentation:

yyyy-xxxxx: serial number

yyyy: year

xxxxx: 5 digit sequential number

3.5 ATEX/IECEX marking

The Alfa Laval Toftejorg MultiJet 50 is certified as category I component. The ATEX certification is carried out by the Notified Body SGS Fimko Oy, who has issued the certificate no. Baseefa10ATEX0188X.

The IECEX certification is carried out by the Certification Body SGS Baseefa Ltd., who has issued the certificate no. IECEX BAS 19.0087X.

Note

Explosion protection type is constructional safety “c”.

The marking on the ATEX/IECEX certified Alfa Laval Toftejorg MultiJet 50 is as follows (for information on marking position see section 3.4 Marking):

Rotary Jet Head

MultiJet 50

s/n.: yyyy-xxxxx



Alfa Laval, DK-6000 Kolding, Albuen 31

II 1G Ex h IIC 85°C...175°C Ga

II 1D Ex h IIIC T85°C...T140°C Da

CE 0598 Baseefa 10ATEX0188X IECEX BAS 19.0087X

Serial number explanation:

Machines supplied with or without standard documentation:

yyyy-xxxxx: serial number

yyyy: year

xxxxx: 5 digit sequential number

3 Introduction

3.6 ATEX/IECEx temperature class and code

The maximum surface temperature depends mainly on operating conditions which are the temperature of the cleaning/mixing fluid and the ambient temperature.

Group II EPL Ga

The gas temperature class is corrected with a safety margin of 80% due to a requirement for Group II EPL Ga equipment. The gas temperature class depends on the cleaning/mixing fluid temperature or the ambient temperature, whichever of the two is the highest.

Table for determining temperature class (gas atmospheres)		
Temperature Class	Cleaning/mixing fluid Temperature, T_p (°C)	Ambient temperature, T_{amb} (°C)
85°C (T6)	$\leq +68^\circ\text{C}$	$\leq +68^\circ\text{C}$
100°C (T5)	$\leq +80^\circ\text{C}$	$\leq +80^\circ\text{C}$
135°C (T4)	$\leq +108^\circ\text{C}$	$\leq +108^\circ\text{C}$
175°C	$\leq +140^\circ\text{C}$	$\leq +140^\circ\text{C}$

Group III EPL Da

The dust temperature class depends on the cleaning fluid temperature or the ambient temperature, whichever of the two is the highest.
No dust layer is considered.

Table for determining temperature class (dust atmospheres)		
Temperature code	Cleaning/mixing fluid Temperature, T_p (°C)	Ambient temperature, T_{amb} (°C)
T85°C	$\leq +85^\circ\text{C}$	$\leq +85^\circ\text{C}$
T100°C	$\leq +100^\circ\text{C}$	$\leq +100^\circ\text{C}$
T135°C	$\leq +135^\circ\text{C}$	$\leq +135^\circ\text{C}$
T140°C	$\leq +140^\circ\text{C}$	$\leq +140^\circ\text{C}$

Example of gas class determination

Cleaning/mixing fluid temperature is 67°C and ambient temperature is 75°C.
Gas class = T5

ATEX/IECEx marking on the equipment:



II 1G Ex h IIC 85°C...175°C Ga
II 1D Ex h IIIC T85°C...T140°C Da

3.7 Quality system

The Alfa Laval Toftejorg tank cleaning machines are produced according to Alfa Laval Kolding's ISO 9001 international Standard certified quality system.

4.1 General Description

The Alfa Laval Toftejorg MultiJet 50 is a media driven and media lubricated tank cleaning machine. As it is self lubricating, there is no lubricating substances such as oil, grease etc. in the machine which needs to be regularly changed.

For use in explosive hazard zones the ATEX/IECEX version can be used, provided it is installed according to safety instructions in local regulations.

4.2 Functioning

The flow of the cleaning fluid passes through a guide and a turbine, which accordingly is set into rotation. The turbine rotation is through a gearbox transformed into a combined horizontal rotation of the machine body and a vertical rotation of the nozzles.

Machines with 2 nozzles

The combined motion of the machine body and the nozzles ensures a fully indexed tank cleaning coverage. After $11\frac{1}{4}$ revolutions of the Hub with nozzles ($10\frac{3}{4}$ revolutions of the machine body), one coarse cleaning pattern is laid out on the tank surface. During the following rounds, this pattern is repeated 3 times, each of which is displaced $\frac{1}{4}$ of the mesh in the pattern. After a total of 45 revolutions of the Hub with nozzles (43 revolutions of the machine body), a complete cleaning pattern has been laid out, and the first pattern is repeated.

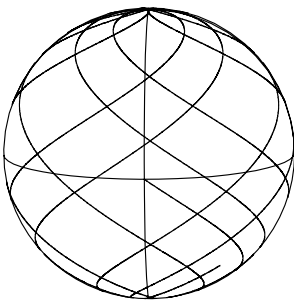

First cycle

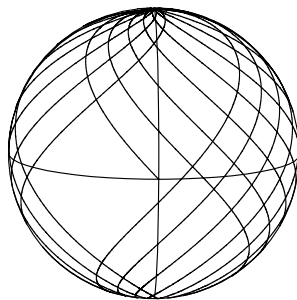

Second cycle

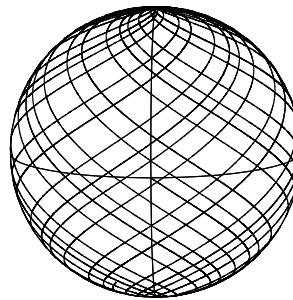

Third cycle

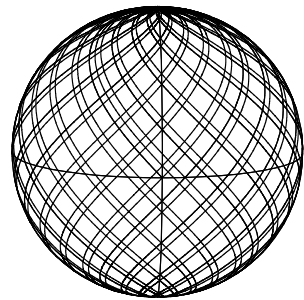

Forth cycle

4 Installation

Machines with 4 nozzles

The combined motion of the machine body and the nozzles ensures a fully indexed tank cleaning coverage. After $5 \frac{5}{8}$ revolutions of the Hub with nozzles ($5 \frac{3}{8}$ revolutions of the machine body) one coarse cleaning pattern is laid out on the tank surface. During the following rounds, this pattern is repeated 7 times, each of which is displaced $\frac{1}{8}$ of the mesh in the pattern. After a total of 45 revolutions of Hub with nozzles (43 revolutions of the machine body), a complete cleaning pattern has been laid out, and the first pattern is repeated.

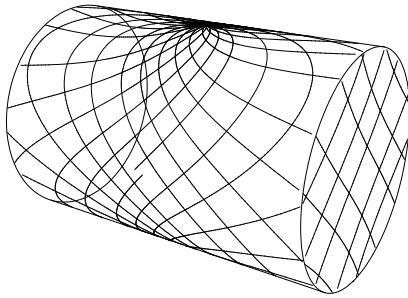

First cycle

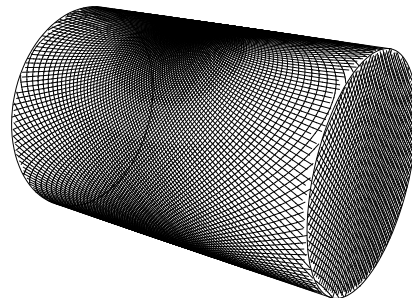

Full pattern

In general for both 2 and 4 nozzle machines

The speed of rotation of the turbine depends on the flow rate through the machine. The higher the flow rate the higher the speed of rotation will be. In order to control the RPM of the machine for a wide range of flow rates, the efficiency of the turbine can be changed (100% and 0% Turbine/Inlet guide).

Apart from the jet flow through the nozzles, fluid is leaking through the top of the machine, at the hub and through the bottom cover. The leakage between the moving parts at the top and at the hub are cleaning the gabs and thus preventing build-up of material that might cause the friction. The flow through the bottom cover is due to the fact that the machine is media lubricated and that accordingly a flow through the gearbox is needed.

4.3 General Safety and Installation Instructions

The tank cleaning machine should be installed in a vertical position (upright or upside down). It is recommended to install a filter with a mesh size of max. 3 mm in the supply line in order to avoid large particles to clog inside the machine. Before connecting the machine into the system, all supply lines and valves should be flushed to remove foreign matter.

NOTE

The machine shall be installed in accordance with national regulations for safety and other relevant regulations and standards. In EU-countries the complete system must fulfil the EU-machine Directive and depending of application, the EU-Pressure Equipment Directive, the EU-ATEX/IECEX Directive and other relevant Directives and shall be CE-marked before it is set into operation.

Warning:

Precautions shall be made to prevent starting of the cleaning operation, while personnel are inside the tank or otherwise can be hit by jets from the nozzles.

For information on use in potential explosive atmospheres see paragraph 4.4 Specific conditions for safe use in accordance with ATEX/IECEX certification page 50.

To protect your tank coating it is recommended to mount bumpers on the tank cleaning machine.

4 Installation

The machine as delivered has been tested at the factory before shipping. For transportation reasons, the nozzles have been screwed off after the test. In order to secure the nozzles against falling off due to vibrations and other external strains it is important that the nozzles are tightened properly after mounting. If not, the nozzles may be blown off during tank cleaning and cause severe damage on tank, valves and pump. This is especially important if machines are fixed installed in tanks and vessels within the transportation sector in trucks, railcars and onboard ships.

Normally, it is sufficient to tighten the nozzles with the specified torque. However, depending on the application and local policies an extra securing may be preferred.

Subject to the intended use, environment and any inhouse user requirements or policies, a liquid threadlocker such as Loctite No. 243 or equivalent could be used. Other methods could be acceptable and subject to customer preference. For detailed instruction on pre-cleaning and application of the product carefully follow the instruction on the used locking system.

Method for tightening the nozzles

1. Clamp machine firmly in a vice. Protect machine with rubber pad under the machine and use rubber jaws on the vice. Mount jaws upside down to ensure firm grip on the machine. Set torque wrench at the specified tightening torque.
2. Hold one nozzle with flat spanner to counteract while tightening the opposite nozzle with the torque wrench.

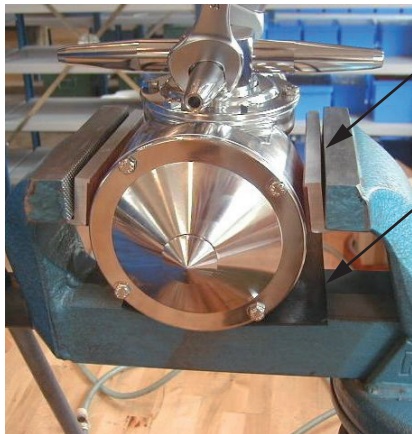

Rubber jaw mounted upside down

Protect with rubber pad



Recommended tightening torque: 50 Nm

3. Check that the machine is in operating condition by inserting Hex Screwdriver (tool No. TE134A) in screw in top of Turbine shaft and easily turn Turbine shaft clockwise. If any resistance is recognised, the machine should be disassembled to localise the cause.

4.4 Specific conditions for safe use in accordance with ATEX/IECEx certification

Directive 2014/34/EU

NOTE

Explosion protection type is constructional safety “c”.

Warning: Operated in a hazardous area



The unit may be operated in a hazardous area only when completely filled with cleaning fluid/steam. If a medium other than the cleaning fluid/steam is passed through the equipment the flow must not be high enough to cause the equipment to operate.

Warning: Operating guidance



The unit shall be operated in line with guidance provided by IEC/TS 60079-32-1 for tank cleaning.

Warning: Temperature class and ambient temperature range



The maximum surface temperature depends mainly on operating conditions which are the temperature of the cleaning fluid and ambient temperature. The temperature class and ambient temperature range are shown in paragraph 3.6 ATEX/IECEx temperature class and code, page 10.

Warning: Max. permitted temperature



When working:
The maximum permitted cleaning fluid temperature and ambient temperature is 95°C.
When not working:
The maximum permitted ambient temperature is 140°C.

Warning: Draining using compressed air



Draining using compressed air must not be done in ex classified zone.
Draining using compressed air is possible in non ex classified zones (see page 18).

Warning: Earthing



All metal and other conductive or dissipative material should be connected to earth with the exception of very small items.
For further information see IEC/TS 60079-32-1:2013 Explosive atmospheres – Part 32-1: Electrostatic hazards, guidance. With focus on clause 6.2.3, 7.2.1, 7.3, 7.9.2, 13.

Warning: Earthed when in use



The unit must be effectively earthed at all times when in use.

4 Installation

4.4 Specific conditions for safe use in accordance with ATEX/IECEx certification

Warning: Max. permitted steaming temperature



The maximum permitted steam temperature through the machine and ambient temperature is 140°C.

Warning: Steaming tanks larger than 100 m³



Tanks with capacities larger than 100 m³ that could contain a flammable atmosphere should not be steam cleaned, as steam cleaning tanks produces an electrostatically charged mist. Tanks smaller than 100 m³ may be steam cleaned.

For further information see IEC/TS 60079-32-1:2013 Explosive atmospheres – Part 32-1: Electrostatic hazards, guidance. With focus on clause 7.10 and 8.5.

Tank size information

The tank cleaning machine has been certified by accredited notified body and can operate in tanks having an enclosed volume up to 100 m³ as long as all ATEX/IECEx warnings in the instruction manual are complied with.

General guidelines for tanks larger than 100 m³:

Tanks larger than 100 m³ must not be steam cleaned – See guide IEC/TS 60079-32-1:2013 clause 7.10.5 and 8.5

To use the unit in tanks larger than 100m³ is possible under certain conditions.

It is necessary to know the current factors such as tank size, cleaning solvent and product.

Additives can be used in the cleaning solvent, or, for example, the tank can be filled with nitrogen. The basic guidelines are described in the guide IEC/TS 60079-32-1:2013.

It must be ensured that the equipollently bonding of all conductive metal objects is in accordance with national regulations for use.

The cleaning fluid conductivity must correspond to the products in the group “High conductivity”, cf. IEC/TS 60079-32-1:2013 clause 7.1 and 7.2.

High conductivity	> 10 000 pS/m
Medium conductivity	between 25 × εr pS/m and 10 000 pS/m
Low conductivity	< 25 × εr pS/m

For liquids with a dielectric constant of around 2, (e.g. hydrocarbons), these classifications reduce to:

High conductivity	> 10 000 pS/m
Medium conductivity	between 50 pS/m and 10 000 pS/m
Low conductivity	< 50 pS/m

Following a guidance document such as IEC/TS 60079-32-1:2013 to establish safe use of machinery and process is the users own responsibility and is not covered by the ATEX/IECEx certification for this unit except for tanks up to 100 m³. For further information see IEC/TS 60079-32-1:2013 Explosive atmospheres – Part 32-1: Electrostatic hazards, guidance with focus on clause 7.1.3, 7.1.4, 7.2.1, 7.2.4.

4.4 Specific conditions for safe use in accordance with ATEX/IECEx certification

Warning: Process generated electrostatic



The user must address the electrostatic hazards generated from the process of the equipment in accordance with guidance document IEC/TS 60079-32-1:2013.

Warning: Electrostatically charged liquid



Liquids can become electrostatically charged when they move relative to contacting solids or the spraying of liquids can also create a highly charged mist or spray. The liquid must be made electrically conductive by additives or otherwise.

For further information see IEC/TS 60079-32-1:2013 Explosive atmospheres – Part 32-1: Electrostatic hazards, guidance. With focus on clause 7.1.3, 7.1.4, 7.2.1, 7.2.4.

Warning: Appropriate cleaning fluid



The cleaning fluid should be appropriate for the application (e.g. so no chemical reaction can take place between the cleaning fluid and the residue of process fluid/powder/compound which can generate heat or a hybrid mixture).

Chemical reactions in Zone 20 - Hybrid mixtures:

End-user must ensure that the cleaning fluid used does not create a hybrid mixture according to IEC 60079-10-1:2015 Annex I.1 in connection with powder / dust residues in the tank in zone 20.

This should ensure that the atmosphere does not change to a classification that lies outside the machine's certified scope. When the machine is used for cleaning tanks containing potentially flammable dust atmospheres, and a potentially flammable fluid is used as the cleaning fluid then an assessment of the hybrid mixture shall be undertaken by the user, prior to operation.

For further information see IEC 60079-10-1:2015 Explosive atmospheres – Part 10-1: Classification of areas – Explosive gas atmospheres. With focus on clause 3.6.6 and Annex I – Hybrid mixtures.

Warning: Fluid pressure



The maximum permitted cleaning fluid pressure is 12 bar.

In addition to the above mentioned precautions relating to Directive 2014/34/EU, the Safety Precautions on page 13 must be observed.

5 Operation

5.1 Normal operation

Cleaning Media

Use only cleaning media compatible with stainless steel AISI 316/316L, Carbon, PTFE, Tefzel and PVDF. Normal detergents, moderate solutions of acids and alkalis will be acceptable. Aggressive chemicals, excessive concentrations of chemicals at elevated temperatures, as well as certain dissolvents and hypochlorides should be avoided. If you are in doubt, contact your local Alfa Laval sales office.

Pressure

Avoid hydraulic shocks. Increase pressure gradually. Do not exceed 12 bar inlet pressure. Recommended inlet pressure appears from Technical Data (page 38). High pressure in combination with high flow rate increase consumption of wear parts. High pressure also reduces the cleaning effect.

Draining using compressed air

If the machine is drained using compressed air, then the compressed air pressure must not cause the machine body rotation to exceed 1.5 rpm (corresponding to approx. 40 sec. per rev of the body) in order to avoid risk of machine breakdown.

Draining should always be done inside the tank.

See paragraph 4.4 Specific conditions for safe use in accordance with ATEX/IECEX certification (page 15).

Steam cleaning

If steam cleaning is done through the machine, the steam pressure must not cause the machine body rotation to exceed 17 rpm (corresponding to approx. 3.5 sec. per rev of the body) in order to avoid risk of machine breakdown. See paragraph 4.4 Specific conditions for safe use in accordance with ATEX/IECEX certification (page 15).

Temperature

The maximum recommended cleaning fluid is 95°C. The maximum recommended steam temperature is 140°C. The maximum ambient temperature is 140°C.

See paragraph 4.4 Specific conditions for safe use in accordance with ATEX/IECEX certification (page 15).

After use cleaning

After use flush the machine with fresh water. Cleaning media should never allow to dry or settle in the system due to possible "salting out" or "scaling" of the cleaning media. If cleaning media contains volatile chloride solvents, it is recommended **not to flush with water** after use, as this might create hydrochloric acid.

5.2 Safety precautions

The machine is intended for use inside a tank only. As peak velocity of main jets reaches 40 m/sec., The Alfa Laval Toftejorg MultiJet 50 must not be operated in open air or when tank is open.

Warning:



Hot chemicals and steam under pressure may be used for cleaning and sterilising. Protect against scalding and burning. Never tamper with or try to open clamps or other connections while system is in operation. Make sure that system is depressurised and drained before disassembly.

The cleaning jets impinging the tank surface are a source of noise. Depending on pressure and distance to the tank walls, noise level may reach up to 85 dB.

Warning:



Tanks may contain poisonous/hazardous products or products which represent an environmental or safety risk. Never open tank and dismount the machine without checking previous tank contents and necessary precautions.

See also 3.6 ATEX/IECEx temperature class and code, page 10.

6 Maintenance

6.1 Service and repair of ATEX/IECEX certified machines

Warning:



All service and repair of ATEX/IECEX certified machines can be performed by Alfa Laval Kolding A/S, Denmark, or by an Alfa Laval service center approved by Alfa Laval Kolding A/S.

Changes to the machine are not allowed without approval by the person responsible for the ATEX/IECEX certification at Alfa Laval. If changes are made – or spare parts other than Alfa Laval original spare parts are used - the EC Type Examination certification (the ATEX/IECEX Directive) is no longer valid.

In order to ensure compliance with the ATEX/IECEX regulations and keep the machine ATEX/IECEX certification valid, the service or repair must be performed by an authorized person with knowledge of the ATEX/IECEX requirements and regulations. All spare parts must be original Alfa Laval spare parts and the repair or service must be done according to the instructions in this manual.

If a customer wishes to carry out service or repair himself, it is the responsibility of the repair shop to ensure that the ATEX/IECEX requirements are met in any way possible. After performing service or repair, the repair shop thus carries the full responsibility for traceability of all relevant documents in order to ensuring the retention of the ATEX/IECEX certification of the machine.

6.2 Preventive Maintenance

In order to keep your tank cleaning machine servicing you as an efficient tool in your tank cleaning operations, it is essential to maintain its high performance by following a simple preventive maintenance programme, which will always keep your tank cleaning machine in good condition.

Good maintenance is careful and regular attention!

The following recommended preventive maintenance is based on tank cleaning machines working in average conditions. However, you will appreciate that a tank cleaning machine, which has a rough and dirty job to do, will need more frequent attention than one working in ideal conditions. We trust that you will adjust your maintenance programme to suit.

Always use only proper tools. Use standard tool kit. Never force, hammer or pry components together or apart. Always perform all assembly/disassembly steps in the order described in this manual.

Never assemble components without previous cleaning. This is especially important at all mating surfaces. Work in a clear well lighted work area.

Note: Recommended tightening torque for all screws: 4-5 Nm.

Every 300 working hours

1. Disassemble machine as described on the following pages.
2. Clean material build-up and deposits from internal parts with chemical cleaner and fine abrasive cloth.
3. Check Slide bearings (pos. 30 on the cross sectional drawing, page) for wear. If hole is worn oval to max. diameter more than 12.4 mm, Slide bearing should be replaced. If end face of Slide bearing is worn more than x mm into Slide bearing, it should be replaced.

Under Turbine shaft:	x = 1.5 mm
At Horizontal shaft:	x = 0.5 mm

4. Check Collar bushes (pos. 12) in Gear frame. If holes are worn oval to max. diameter more than 15.4 mm, Collar bush should be replaced. How to replace Collar bushes, see page 32.

Note: Timely replacement of Slide bearings and Collar bushes will prevent costly damage to the gear box.

5. Check Worm wheels (pos. 13 and pos. 14). If extremely worn, they should be replaced.
6. Check Main bush (pos. 6). If worn oval to max. diameter more than 15.4 mm, it should be replaced.
7. Assemble machines as described in the following pages.
8. Check that the machine is in operating condition by inserting hex Screwdriver (tool No. TE134A) in screw in top of Turbine shaft and easily turn Turbine shaft clockwise. If any resistance is recognized, the machine should be disassembled to localize the cause.

Apart from the parts specifically mentioned above, all the remaining wear parts should regularly be inspected for wear. Which parts that are wear parts appear from Reference Lists of Parts, page 48 and 50.

6 Maintenance

6.3 Top Assembly

Disassembly

1. Remove Screws (pos. 10). Loosen with Key (tool No. TE135) and unscrew with Screwdriver (tool No. TE135A).
2. Lift off Nipple (pos. 1).
3. Remove Guide /Guide ring (pos. 2). The Guide has a groove in the outer diameter. The Guide is easily lifted out of the Stem by means of two ordinary Screwdrivers inserted into the groove.
4. Remove Screw (pos. 17), Spring washer (pos. 16) and Washer (pos. 18). To secure Impeller against rotation, insert carefully Screwdriver (tool No. TE135A), through Impeller (pos. 4) into a hole in the Stem.
5. Pull off Impeller (pos. 4).

Reassembly

1. Reinstall Impeller (pos. 4). Make sure that Impeller is correctly rotated to be pushed onto Turbine shaft. Do not try to hammer Impeller in position, as this will damage Slide bearing under Turbine shaft.
2. Mount Washer (pos. 18), Spring washer (pos. 16) and Screw (pos. 17) and tighten. To secure Impeller against rotation insert carefully Screwdriver (tool No. TE135A) through Impeller (pos. 4) into a hole in the Stem.
3. Reinstall Guide/Guide ring (pos. 2).
4. Mount Nipple (pos. 1). Make sure that it is in correct position over Guide/Guide ring (pos. 2) Rotate Nipple to align holes in Nipple and Stem.
5. Mount Screws (pos. 10) with Screwdriver (tool No. TE135A). Tighten with Key (tool No. TE135).

Top Assembly

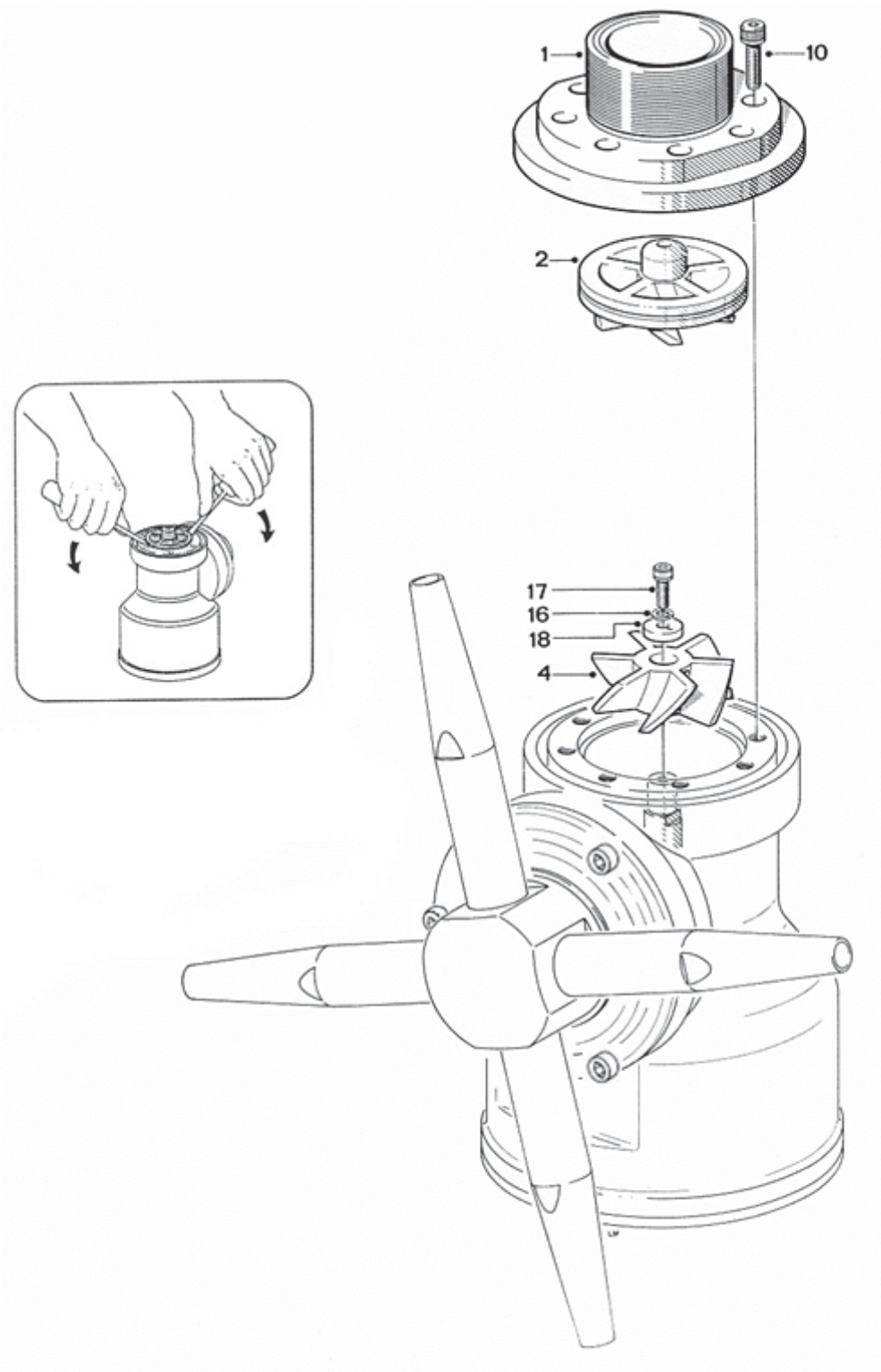

6 Maintenance

6.4 Bottom Assembly

Disassembly

1. Turn machine upside down.
2. Remove Screws (pos. 17) and Spring washer (pos. 16) from Bottom cover (pos. 33).
3. Remove Bottom cover (pos. 33).
4. Remove Screw (pos. 17) and Spring washers (pos. 16) along the circumference of Gear frame (pos. 31). Draw out Gear Subassembly (holes in Gear frame are excellent for holding Gear subassembly).

Reassembly

1. Reinsert Gear subassembly in bottom of machine body. Mount Spring washers (pos. 16) and Screws (pos. 17) along circumference of Gear frame (pos. 31). Tighten screws crosswise.

Note: Turbine shaft is inserted carefully through Gear wheel and Stem. Note also that to secure meshing between Gear wheel (pos. 8) and Pinion (pos. 11) it might be necessary to rotate slightly either the whole Gear subassembly or the Gear wheel.

2. Replace Bottom cover (pos. 33).
3. Mount Spring washer (pos. 16) and Screws (pos. 17) and tighten crosswise.

Bottom Assembly

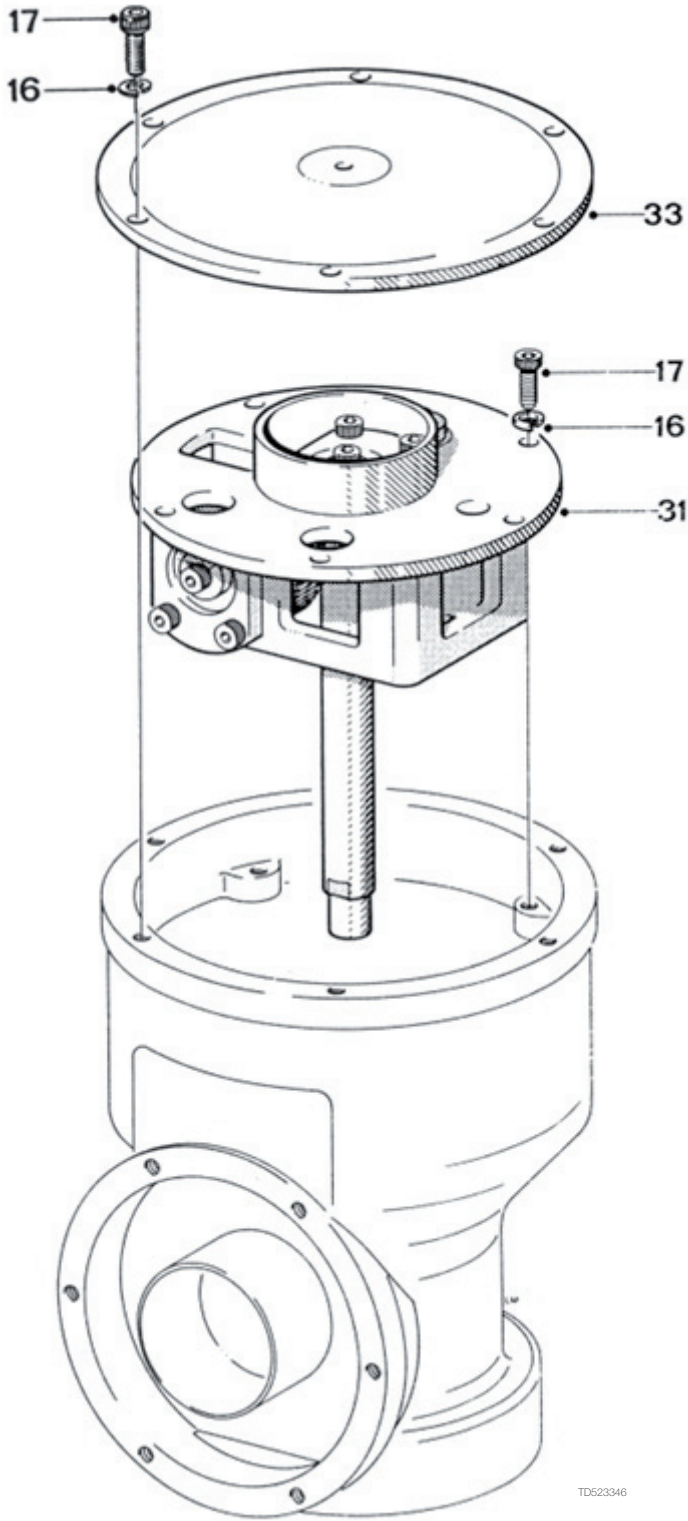

TD523346

6 Maintenance

6.5 Hub Subassembly

Disassembly

1. Remove Nozzles (pos. 22). Nozzles are untightened with a wrench on the faces of the Nozzles.
2. Remove Screws (pos. 17) and Spring washer (pos. 16) from Hub cover (pos. 21).
3. Draw out Hub (pos. 23) together with Hub cover (pos. 21), Ball race (pos. 21.1), Ball retainer with balls (pos. 27) and Bevel gear (pos. 20). If Hub cover (pos. 21) clings into Body, knock carefully with plastic hammer on outer diameter to loosen.

If Ball races (pos. 20.1) and in Bevel gear (pos. 21.1) are extremely worn, they should be replaced as well as the Ball retainer with balls (pos. 27). How to replace Ball races see page 34.

If blue liners on Stem are extremely worn, they can be replaced. This part requires that a precise procedure is followed to accomplish installation. It is highly recommended that an authorized Alfa Laval Tank Equipment Service Center perform the replacement when necessary.

Reassembly

1. Slide on Hub (pos. 23).
2. Mount Bevel gear with race (pos. 20), Ball retainer with balls (pos. 27) and Hub cover (pos. 21) and Hub cover (pos. 21) and set with Spring washer (pos. 16) and Screw (pos. 17).
3. Screw on Nozzles (pos. 22) and tighten with wrench. If desired, secure with liquid threadlocker Loctite No. 243 or equivalent, see page 13.

Hub Assembly

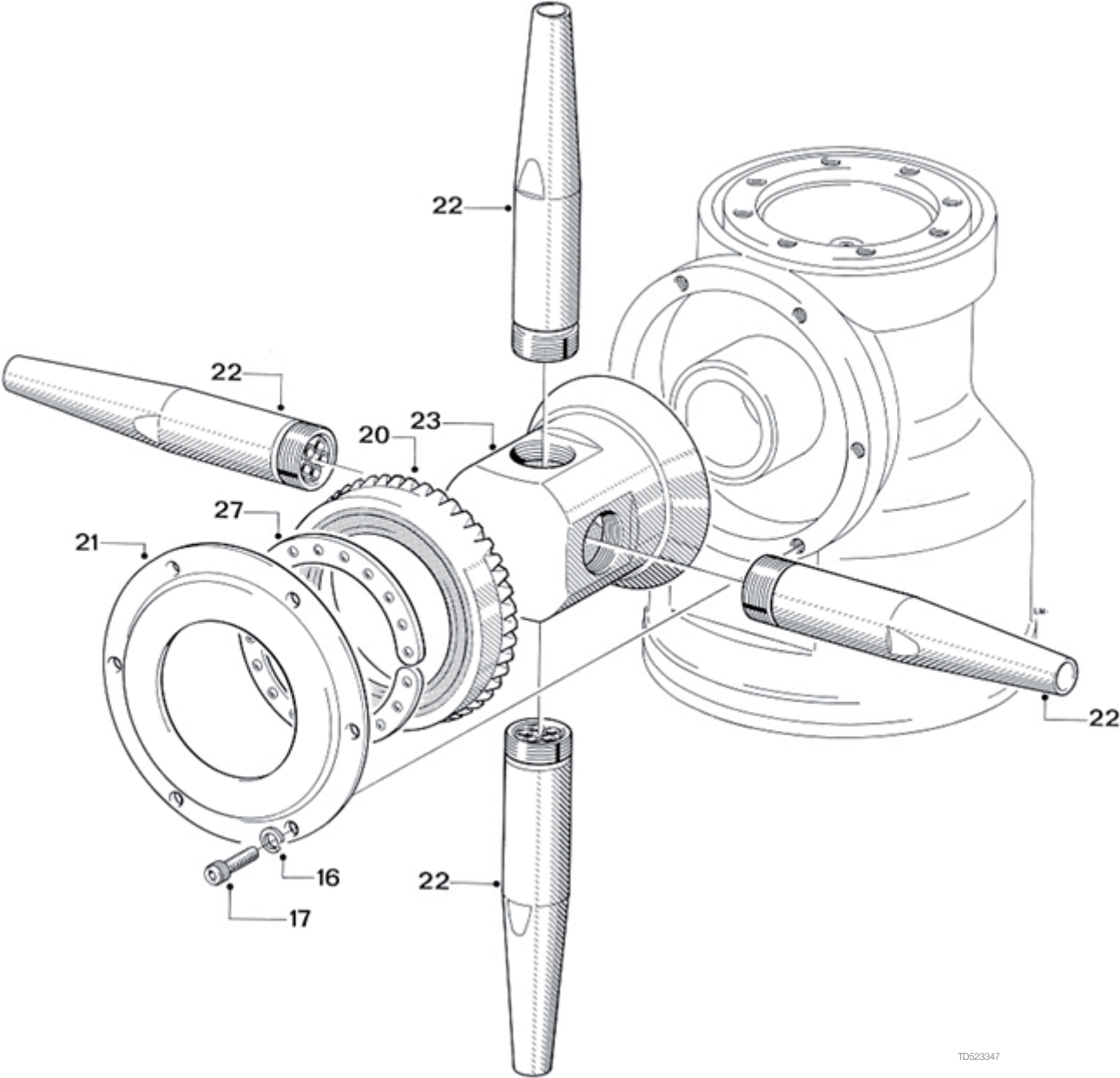

TD523347

6 Maintenance

6.6 Stem Subassembly

Disassembly

1. Place machine in upright position.
2. Unscrew Gland (pos. 5). Note: Left-hand thread. Push out Main bush (pos. 6).
3. Turn machine upside down.
4. Remove Screws (pos. 10) in Gear wheel (pos. 8). To prevent rotation of Stem (pos. 3) mount two screws in two holes opposite one another in BIG end of Stem. Place Stem in a vice held by the heads of the two screws..
5. Draw out Gear wheel with ball race (pos. 8) and Ball retainer with balls (pos. 27).
6. Push out Stem (pos. 3).

If Ball races in Body (pos. 28.3) and on Gearwheel (pos. 8.1) are extremely worn they should be replaced together with Ball retainer with balls (pos. 27). How to replace Ball races see page 34.

If blue liners on Stem are extremely worn, they can be replaced. This part requires that a precise procedure is followed to accomplish installation. It is highly recommended that an authorized Alfa Laval Tank Equipment Service Center perform the replacement when necessary.

Reassembly

1. Push Stem (pos. 3) into Body. Turn machine upside-down.
2. Place Ball retainer with balls (pos. 27) and Gear wheel (pos. 8) into Body on Ball race. Rotate Gear wheel to check free rotation.
3. Mount Gear wheel (pos. 8) with Screws (pos. 10) and tighten crosswise. To prevent rotation of Stem (pos. 3) mount two 1/4" screws in two holes opposite one another in BIG end of Stem. Place Stem in a vice held by the heads of the two screws.
4. Turn machine to upright position. Remount Main bush (pos. 6) in Gland (pos. 5) and screw into Stem (pos. 3). Note: Left-hand thread.

Stem Subassembly

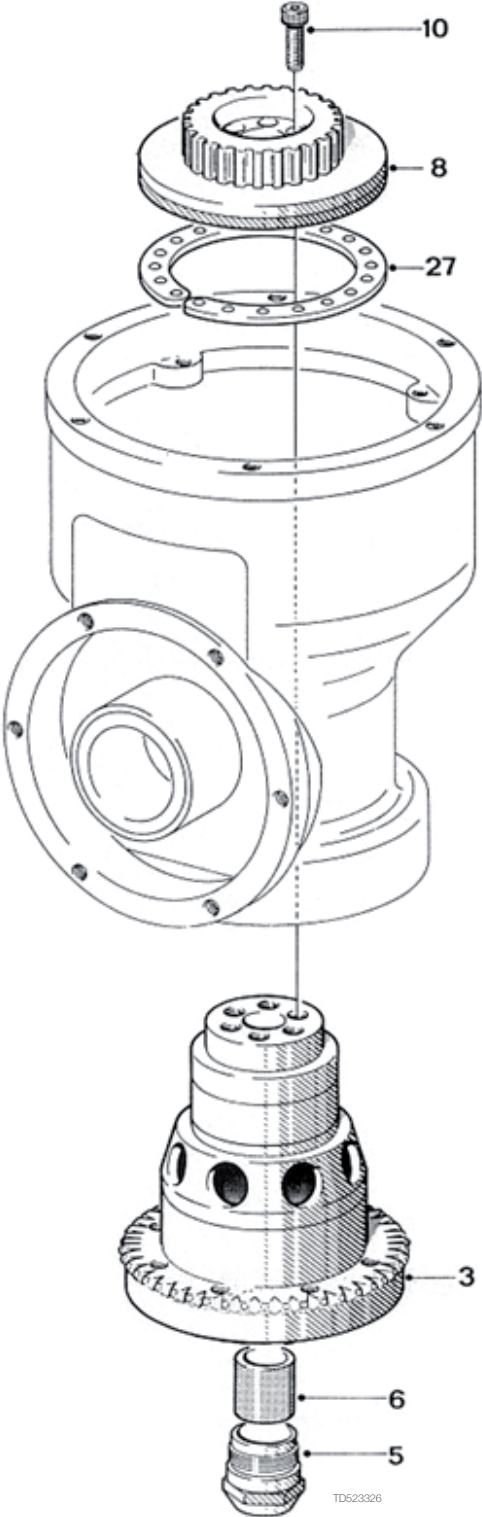

TDS23326

6 Maintenance

6.7 Gear Subassembly

Disassembly

1. Hold Turbine shaft (pos. 7) against 1st stage Worm wheel (pos. 14) with one hand and loosen Screws (pos. 17) in Pinion (pos. 11) and Horizontal shaft (pos. 29) with the other hand.
2. Draw out Turbine shaft (pos. 7) after Screw (pos. 17), Spring Washer (pos. 16) and Washer (pos. 18) has been removed. Use faces on Turbine shaft to hold against rotation.
3. Draw out Horizontal shaft (pos. 29) and 1st stage Worm wheel (pos. 14) after removal of Screw (pos. 17), Spring washers (pos. 16) and Washer (pos. 18).
4. Draw out Pinion (pos. 11) and 2nd stage Worm wheel (pos. 13), also freeing Journal (pos. 15) after removal of Screw (pos. 17), Spring washer (pos. 16) and Washer (pos. 18).
5. Remove Bearing covers (pos. 32) and Slide bearings (pos. 30) after removal of Screw (pos. 17).

How to replace Collar bushes (pos. 12), see page 32.

Warning:



Do not damage driver faces on Turbine shaft. Use only proper tools providing a firm grip such as a wrench or a vice.

Reassembly

1. Push Slide bearing (pos. 30) into Gear frame (pos. 31) and fix Bearing covers (pos. 32) with Screws (pos. 17). Tighten crosswise.
2. Insert 2nd stage Worm wheel (pos. 13), Pinion (pos. 11) and Journal (pos. 15). Mount Washer (pos. 18), Spring washer (pos. 16) and fix with Screw (pos. 17). Check rotation.

Gear Subassembly

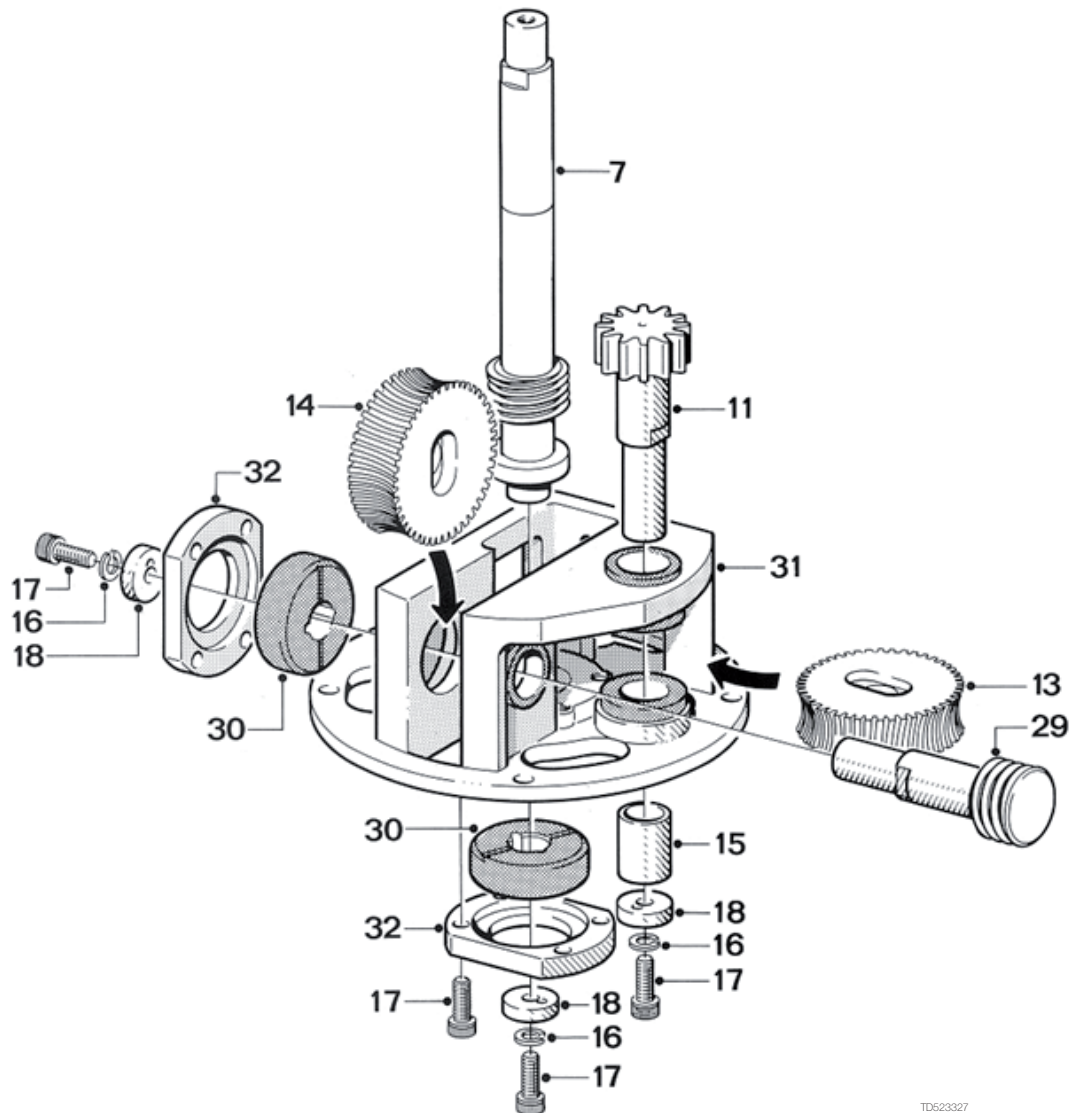

TD623327

3. Insert 1st stage Worm wheel (pos. 14) and Horizontal shaft (pos. 29). Mount Washer (pos. 18), Spring washer (pos. 16) and fix with Screw (pos. 17). Check rotation.
4. Insert Turbine shaft (pos. 7). Mount Washer (pos. 18), Spring washer (pos. 16) and fix with Screw (pos. 17). Use faces on Turbine shaft to hold against rotation when tightening screw.
5. Hold Turbine shaft (pos. 7) against 1st stage Worm wheel and tighten Screws (pos. 17) in Horizontal shaft (pos. 29) and Pinion (pos. 11). Check rotation on Turbine shaft.

6 Maintenance

6.8 Replacement of Collar Bushes

Replacement of Collar Bushes

1. Place Gear frame (pos. 31) upside down with a firm support under the flange. Use for instance jaws of a vice. Do not clamp on machined surfaces. With Pusher (tool No. TE81B031, see page 53) knock out Collar bush.
2. Turn Gear frame to upright position and hold over support such as flat steel bar clamped in a vice. Knock out Collar bush with Pusher.
3. Turn Gear frame 90° and hold over support. Knock out collar bush with Pusher.
4. Remove all remains of old Araldite etc. Holes must be perfectly clean before mounting new Collar bushes. Rinse with chemical cleaner.
5. Coat new Collar bushes with CIBA-GEIGY two component Standard blue Araldite and push into Gear frame.
6. To hold Collar bushes in correct position, insert fixtures (tool No. TE81B032, see page 53) and let harden according to instructions.

Warning:



To avoid risk of deforming Gear frame, it is utmost important that it is supported while the Collar bushes are being knocked out.

Removal of old Collar bushes

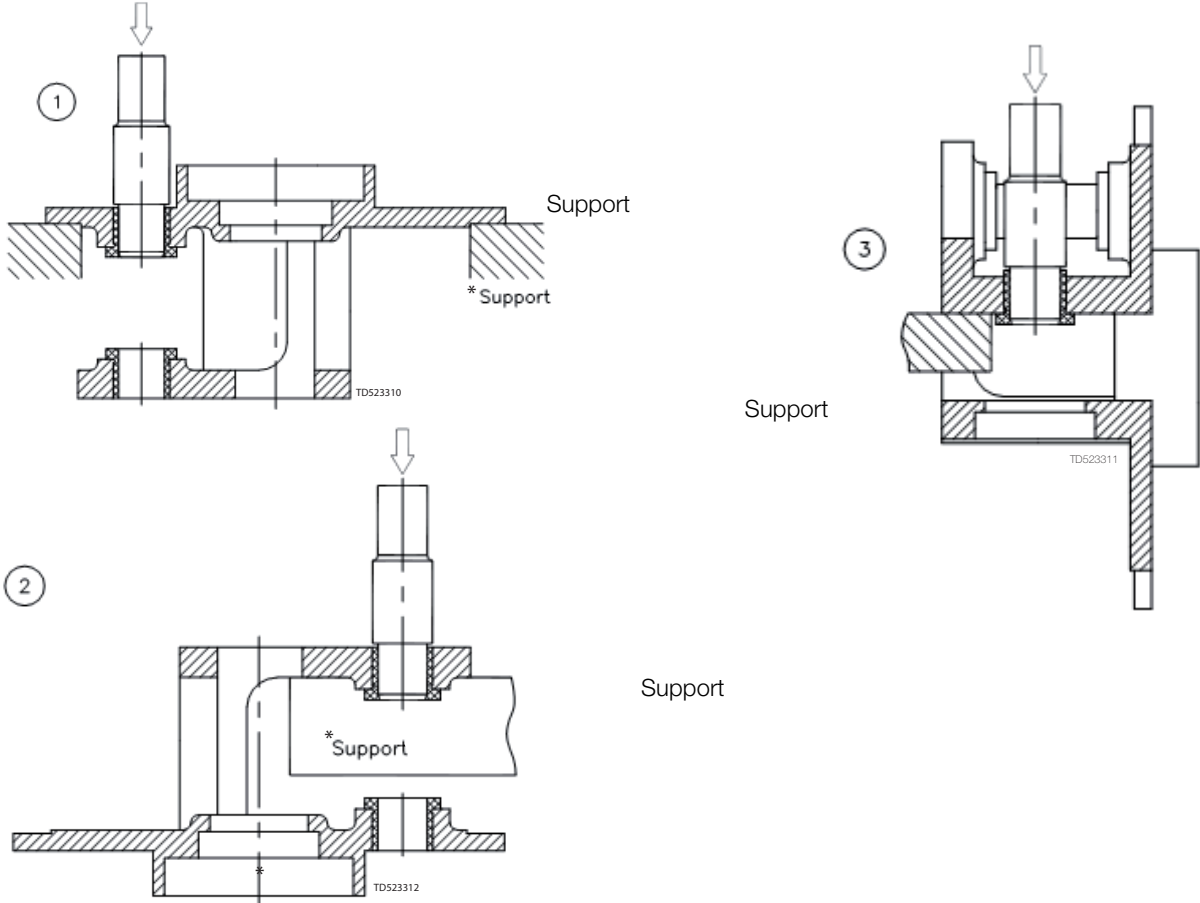

Mounting of new Collar bushes

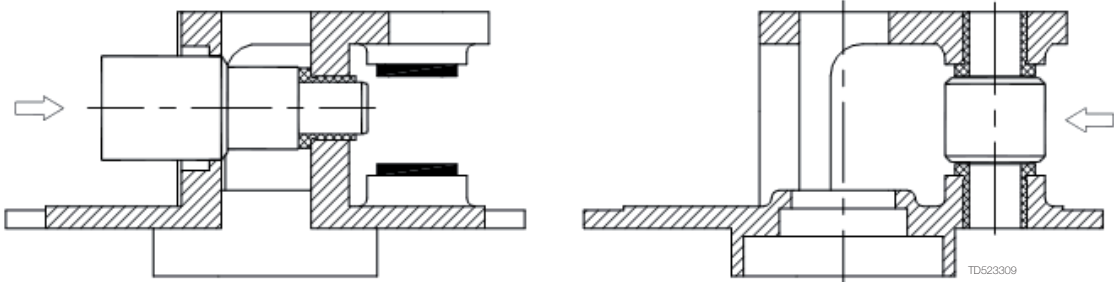

6 Maintenance

6.9 Replacement of Ball Races

In body

1.
 - A. With big end downwards knock several times Body with bearings (pos. 28) hard against firm wooden support until Ball race (pos. 28.3) drops out.
 - B. If it is not possible to knock out Ball race in this way, it is necessary first to screw out Main collar lower (pos. 28.2) – see page 36. Carefully push off old Ball race without damaging Main collar lower. Use mandrel and firm support. Before mounting of new Ball race, Main collar lower (pos. 28.2) must be remounted into Body – see page 36.
2. Clean surfaces and place Ball race (pos. 28.3) on Main collar lower (pos. 28.2). Press by hand as long as possible. By means of a tube mandrel or if desired wooden block, carefully hammer Ball races home.

Ball races must not project over end face of Main collar lower. To avoid tilting mandrel must push along the whole circumference of Ball race. Do not damage surface of Ball race.

On Gear wheel

1. Place Gear wheel with ball race (pos. 8) on support. Support only under Ball race (pos. 8.1). With mandrel press off old Ball race.
2. Clean surfaces and press on new Ball race. Ball race must be pressed fully home on Gear. Press parallel. Use press or vice. Do not damage surface of Ball race.

In Hub cover

1. Place Hub cover with ball race (pos. 21) on support. Carefully knock out old Ball race by means of small mandrel or if desired screwdriver. Knock several times around the circumference to avoid tilting.
2. Clean surfaces and press in new Ball race. Ball race must be pressed fully home. Press parallel. Do not damage surface of Ball race.

Replacement of Ball races

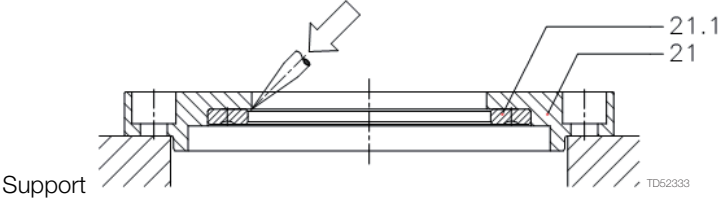
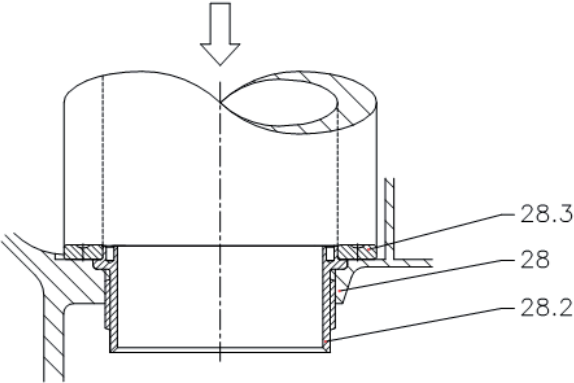
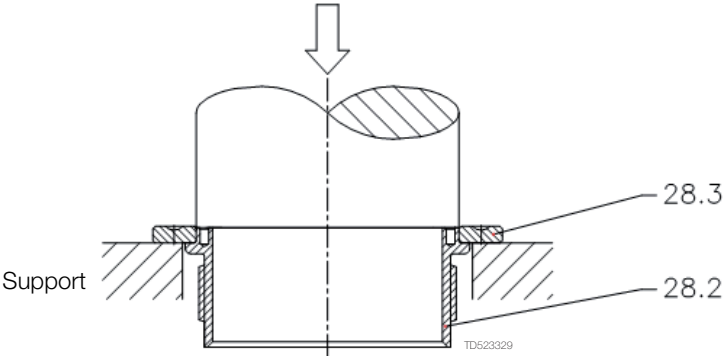

6 Maintenance

6.10 Replacement of Main Collars

Although normally exposed to very limited wear, it is possible to replace Main collars (pos. 28.1 and 28.2) in Body. The procedure to do this is described below.

Warning:



Replacement of Main collars involves risk of damaging the special threads and accordingly the body. It is recommended to let an authorized Alfa Laval sales office do the replacement.

Main collar upper

1. Place Body (pos. 28) in a vice upright position. Do not clamp on machined faces. Insert tool into Main collar upper (pos. 28.1). To loosen Loctite, knock hard on tool with hammer. Unscrew Main collar.
2. Carefully clean thread and recess in Body. Do not damage special thread in Body. Recess must be absolutely clean and free from remains of old Loctite. If desired, use solution of ethylene glycol.
3. Make sure that new Main collar is clean and free from impurities. Apply Loctite No. 243 on thread.
4. Screw in new Main collar. Attention should be given to make sure that thread is in correct engagement before screwing in Main collar.
5. Tighten Main collar fully home. Several times knock hard on tool and tighten up.
6. Check that Main collar is fully home: install Stem, Ball retainer with balls and Gear wheel (see page 28). Check that there is sufficient axial clearance to allow for free rotation of Stem.

Main collar lower

1. Place Body in a vice in upside down position and repeat procedure described above.

Warning: Thread on Main collar lower is left-handed.



Replacement of Main Collars

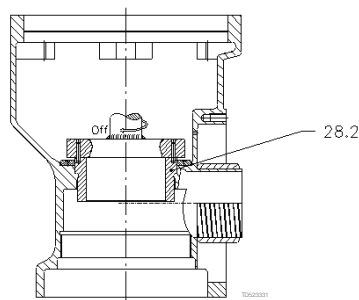
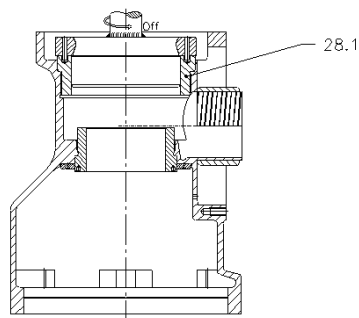

Slow rotation or failure of machine to rotate

Possible Causes	Fault finding
<p>No or insufficient liquid flow</p>	<p>a). Check if supply valve is fully open b). Check if inlet pressure to machine is correct c). Check supply line and filter for restriction/clogging d). Remove Nozzles and check for clogging. If blocked, carefully clean Nozzle without damaging stream straighteners and Nozzle tip. e). Remove Flange/Nipple, Guide and Impeller (see page 22) and check for clogging in Impeller area. If large particles repeatedly get jammed in the machine, install filter or reduce mesh size of installed filter in supply line.</p>
<p>Foreign material or material build-up</p> <p>a). Impeller jammed b). Turbine shaft sluggish in Main bush c). Bevel gears jammed</p> <p>d). Stem jammed/sluggish</p> <p>e). Gearbox jammed/sluggish</p> <p>f). Hub jammed/sluggish</p>	<p>Insert hex Screwdriver in Screw in top of Turbine shaft and easily turn Turbine shaft clockwise. If any resistance is recognised, disassemble machine in order to localise the cause. Remove Guide and Impeller (see page 22) and remove foreign material. Remove gear Assembly (see page 30) and Gland (pos. 5) and clean Main bush. Remove Flange/Nipple and Hub Assembly (see page 26). Clean teeth on Stem and Bevel gear. Remove Gear Assembly (see page 30). Check free rotation of Stem. Remove Stem (see page 28). Remove foreign material/material build-up on Stem and inside Main collars. Clean Ball races and Ball retainer with balls. Also clean main bush. Remove foreign material from Gearbox. Check rotation of shafts. If restriction is recognized, disassemble gearbox (see page 30) and remove material build up, especially on 2. Stage Worm wheel and mating Collar bushes. Disassemble Hub Assembly (see page 26). Remove foreign material inside Hub. Clean Ball races and Ball retainer with balls. Also clean nose of Body.</p>
<p>Wear</p> <p>a) Slide bearings b) Main bush c) Worm wheels d) Collar bushes e) Turbine shaft</p> <p>f) Horizontal shaft</p>	<p>See page 21. See page 21. See page 21. See page 21. Check clearance in Main bush and in Slide bearing. Transverse movement should not exceed 0.5 mm. Also inspect Worm wheel for wear. Check clearance in Collar bushes. Transverse movement should not exceed 0.5 mm. Also inspect worm for wear.</p>
<p>Mechanical defects</p> <p>a). Worm wheels. Teeth broken b). Worm wheel can rotate on Horizontal shaft/Pinion due to damaged driver faces. c). Damaged teeth on gear</p>	<p>Replace Worm wheel. Replace Worm wheel. Inspect teeth on Stem and Hub for deformation. Mount Hub and Stem in Body (see page 26 and 28). Hold Body in upside down position and rotate Hub to check that Bevel gears can work together. If damaged: Replace Stem and/or Bevel gear.</p>

8 Technical data

8.1 Toftejorg MultiJet 50 with 2 nozzles

Weight of machine:	11.3 kg (25.1 lb)
Working pressure:	5-12 bar (72-174 psi)
Recommended inlet pressure:	5-10 bar (72-145 psi)
Working temperature max.:	95°C (200°F)
Ambient temperature:	0 -140°C (95°C - 140°C when not operated)
Materials:	Stainless steel AISI 316/316L, PTFE, Tefzel, PVDF, Carbon

Principal dimensions in mm

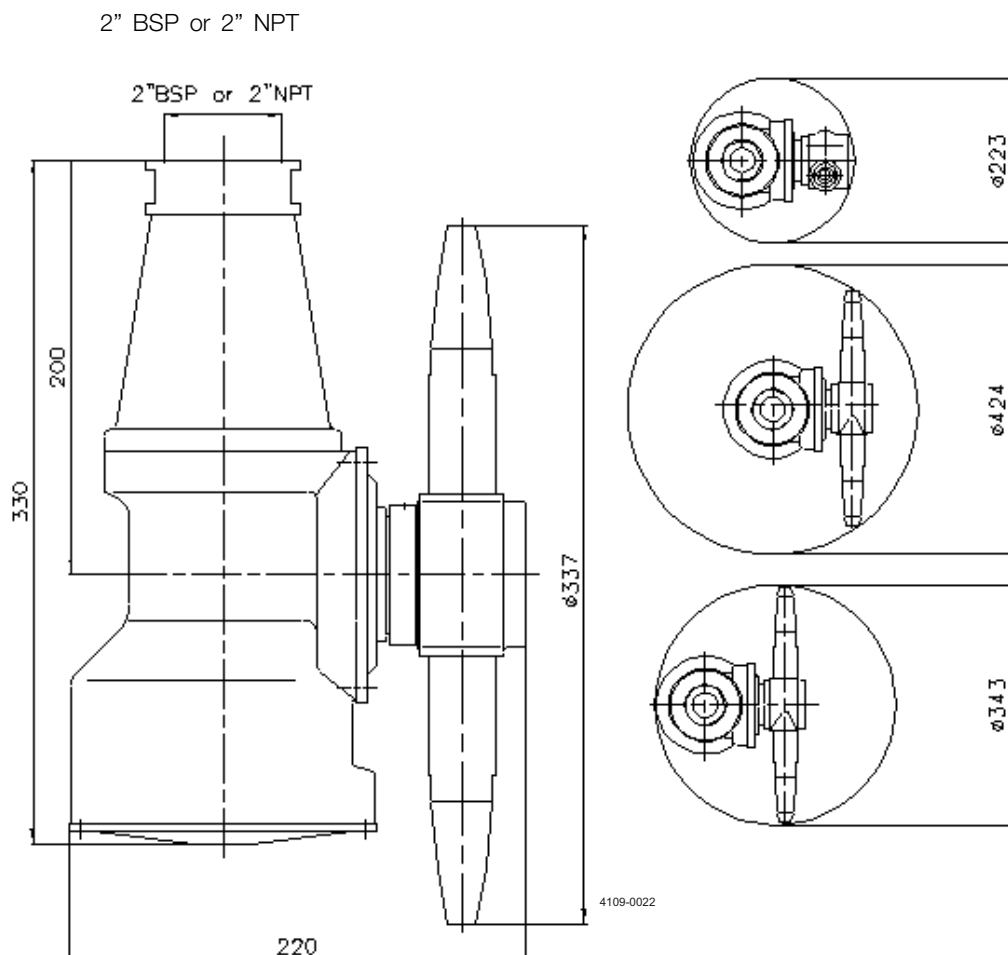

Toftejorg MultiJet 50 with 2 nozzles

Flow rate

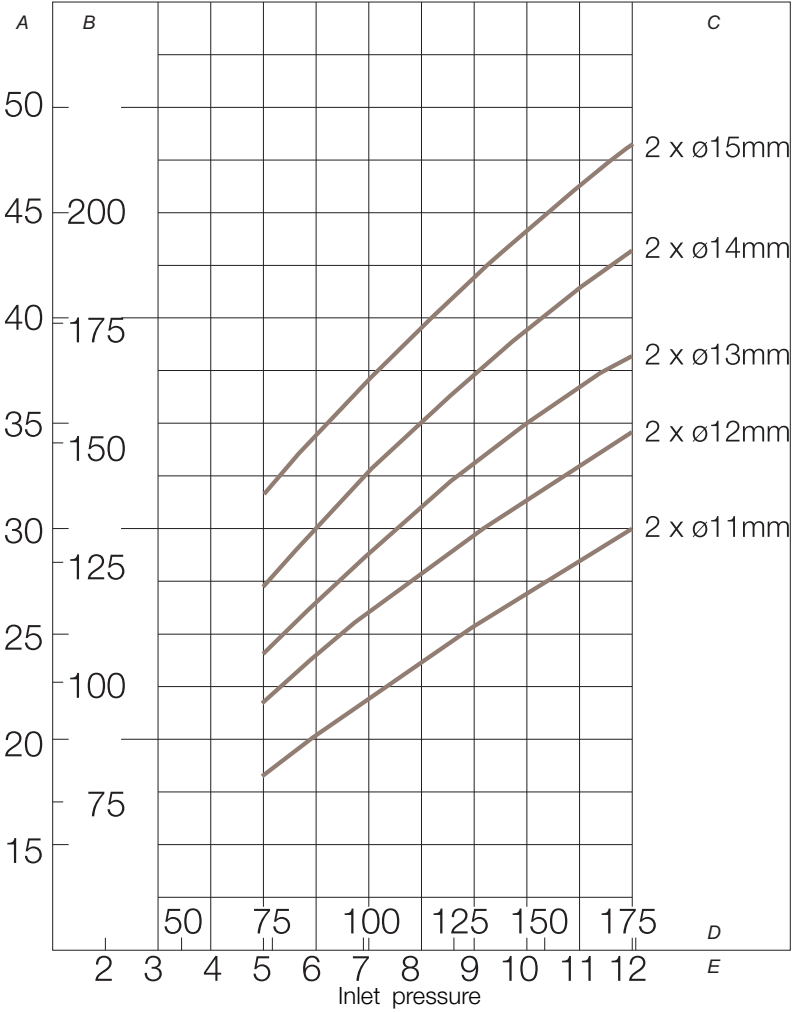

A: m ³ /h	B: USgpm	C: nozzle sizes	D: psi	E: bar
----------------------	----------	-----------------	--------	--------

8 Technical data

Toffejorg MultiJet 50 with 2 nozzles

Throw length

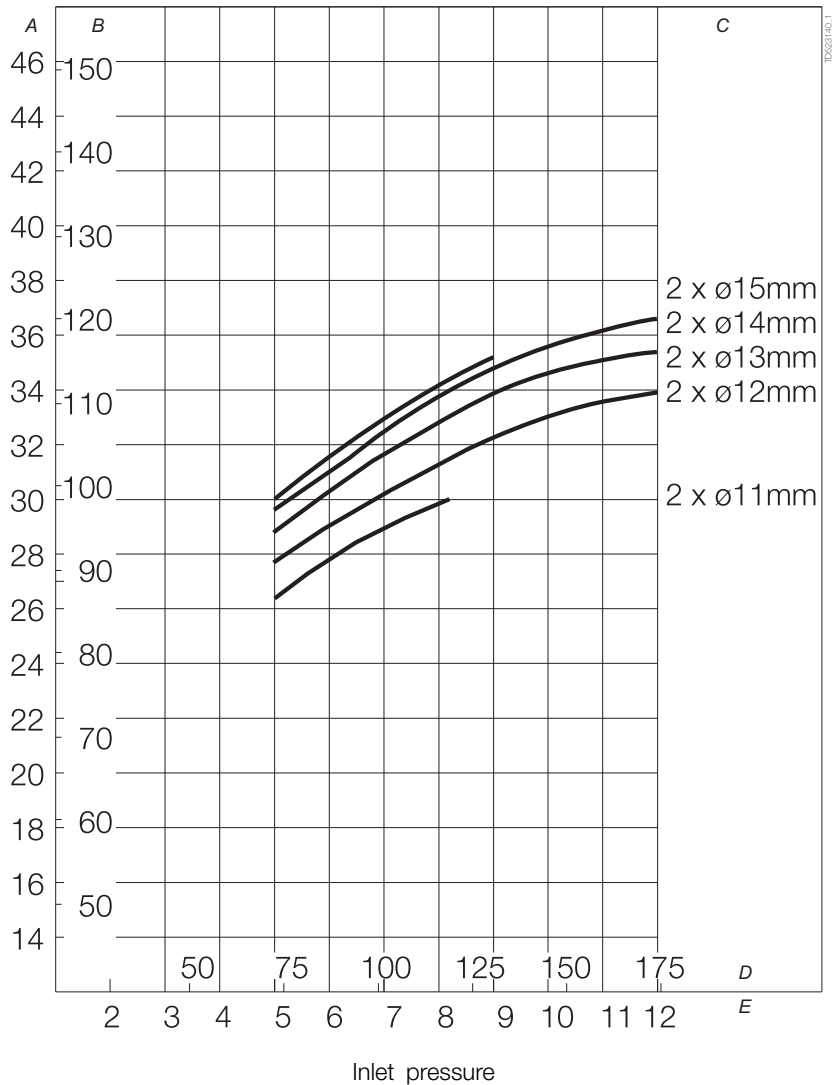

A: m	B: ft	C: nozzle sizes	D: psi	E: bar
------	-------	-----------------	--------	--------

Note: Throw lengths are measured as horizontal throw length at static condition. Vertical throw length upwards is approx. 1/3 less.
 Effective throw length is defined as impact centre of jet 250 mm water column (50 lbs/sq.ft). Effective throw length varies depending on jet transverse speed over surface, substance to be removed, cleaning procedure and agent.
 The inlet pressure has been taken immediately before the machine inlet. In order to achieve the performance indicated in the curves, the pressure drop in the supply lines between pump and machine must be taken into consideration.

Toftejorg MultiJet 50 with 2 nozzles

Cleaning Time, f. complete Pattern (= 4 cycles)

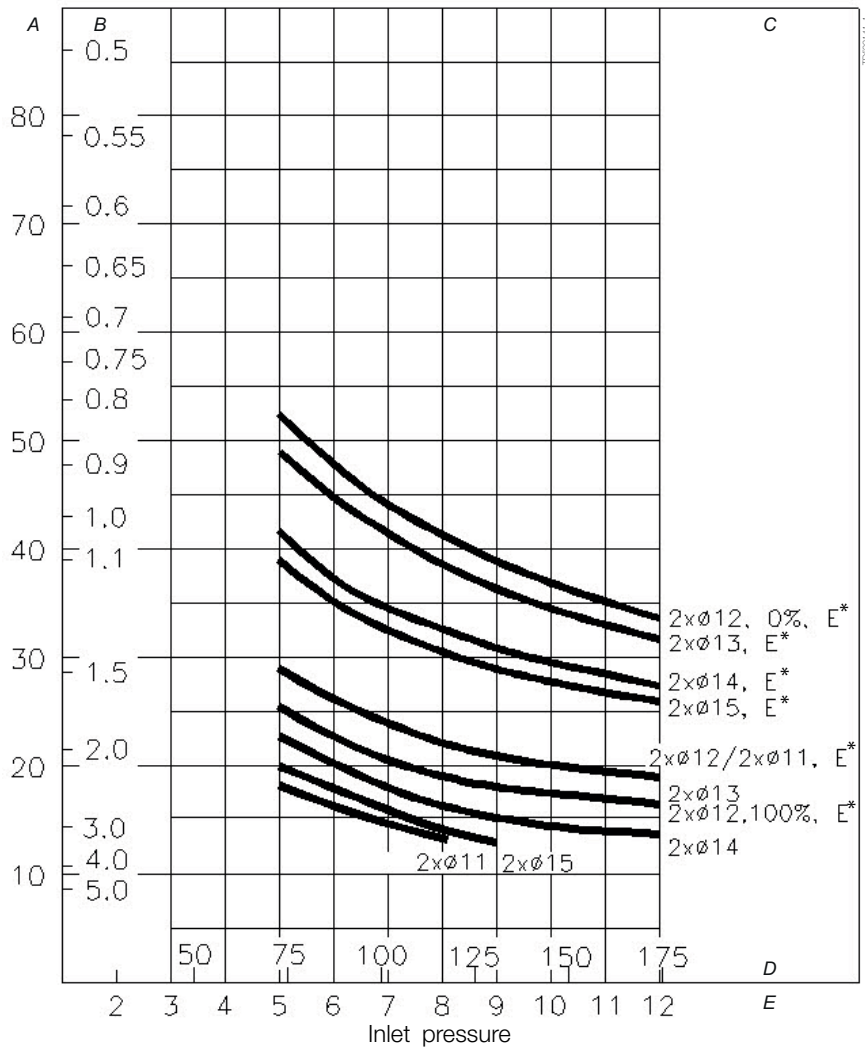

A: min.	B: RPM of machine body	C: nozzle sizes	D: psi	E: bar
---------	------------------------	-----------------	--------	--------

8 Technical data

8.2 Toftejorg MultiJet 50 with 4 nozzles

Weight of machine:	12.2 kg (27 lb)
Working pressure:	3-12 bar (44-175 psi)
Recommended inlet pressure:	5-6.5 bar (72-94 psi)
Working temperature max.:	95°C (200°F)
Ambient temperature:	0 -140°C (95°C - 140°C when not operated)
Materials:	Stainless steel AISI 316/316L, PTFE, Tefzel, PVDF, Carbon

Principal dimensions in mm

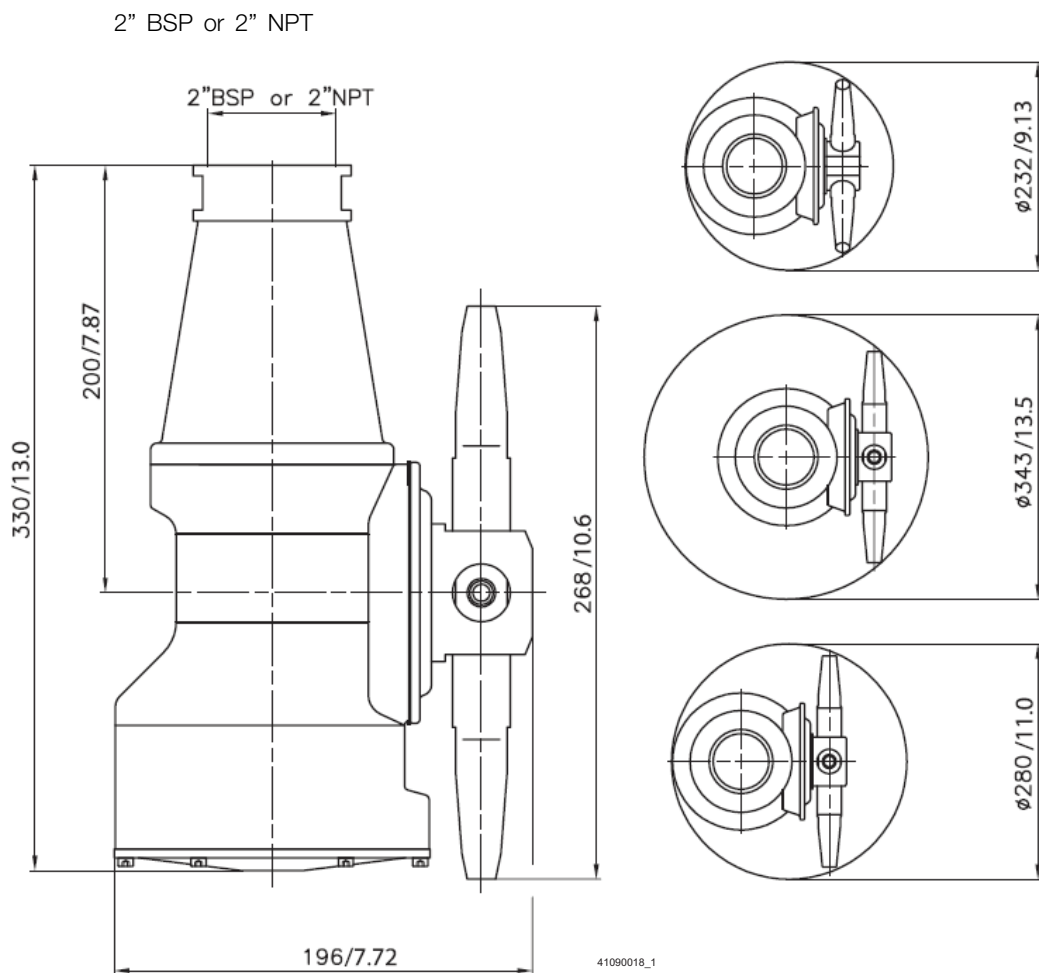

Toftejorg MultiJet 50 with 4 nozzles

Flow rate

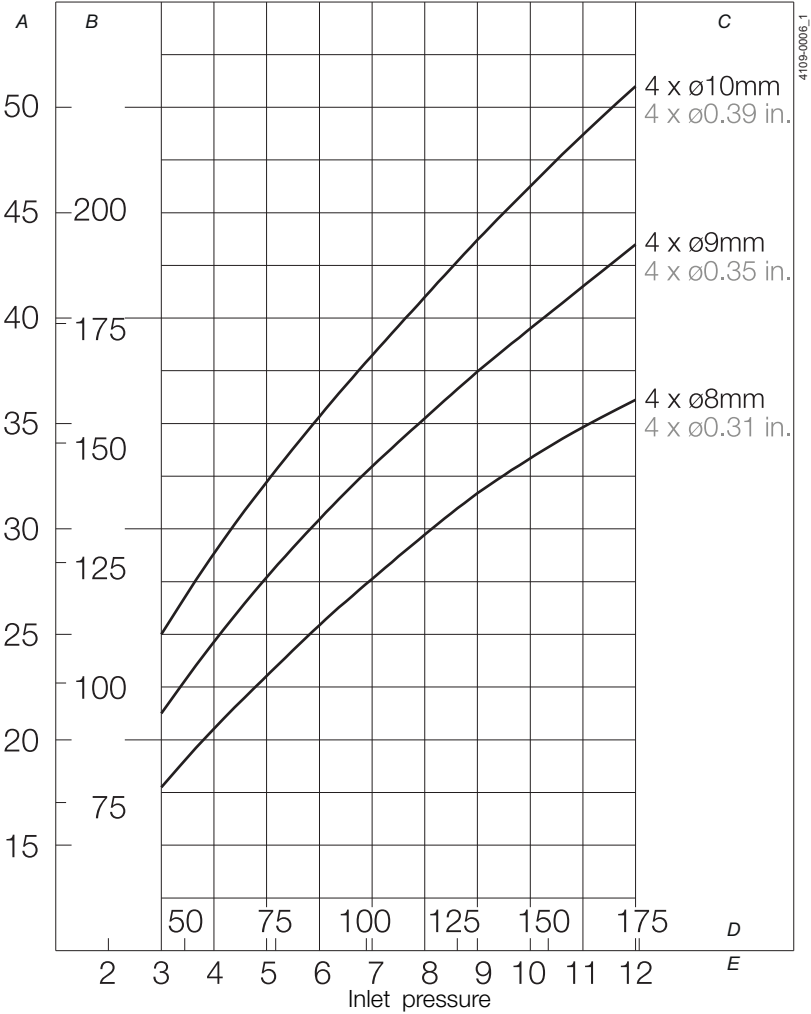

A: m ³ /h	B: USgpm	C: nozzle sizes	D: psi	E: bar
----------------------	----------	-----------------	--------	--------

8 Technical data

Toftejorg MultiJet 50 with 4 nozzles

Throw length

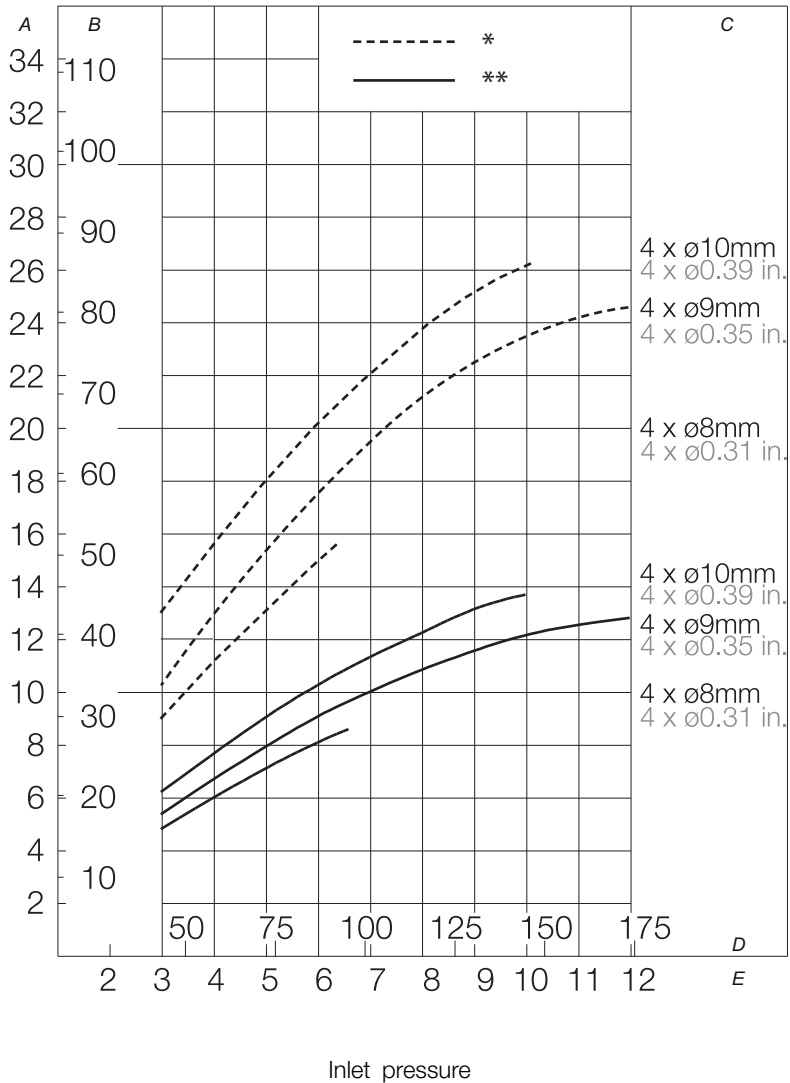

A: m	B: ft	C: nozzle sizes	D: psi	E: bar	* Max. static	**Effective
------	-------	-----------------	--------	--------	---------------	-------------

Note: Throw lengths are measured as horizontal throw length at static condition. Vertical throw length upwards is approx. 1/3 less.
 Effective throw length is defined as impact centre of jet 250 mm water column (50 lbs/sq.ft). Effective throw length varies depending on jet transverse speed over surface, substance to be removed, cleaning procedure and agent.
 The inlet pressure has been taken immediately before the machine inlet. In order to achieve the performance indicated in the curves, the pressure drop in the supply lines between pump and machine must be taken into consideration.

Toftejorg MultiJet 50 with 4 nozzles

Cleaning Time, f. complete Pattern (= 8 cycles)

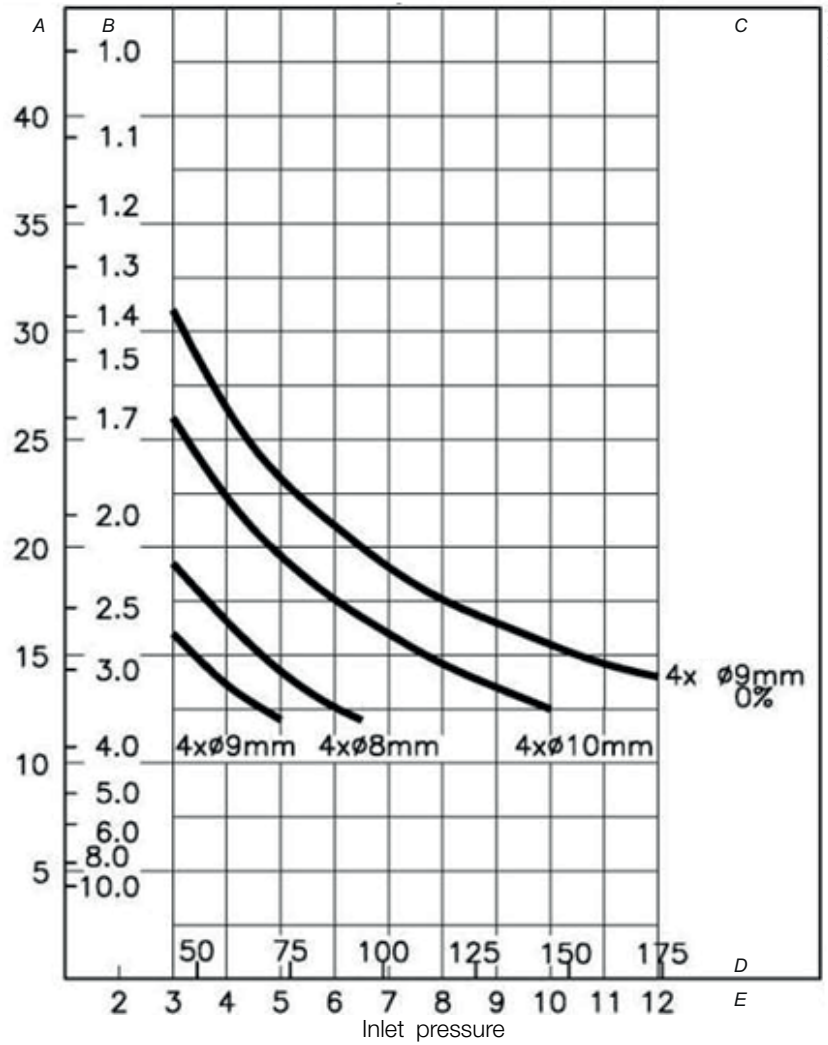

A: min.	B: RPM of machine body	C: nozzle sizes	D: psi	E: bar
---------	------------------------	-----------------	--------	--------

9 Product programme

9.1 Standard Configurations

Standard configurations, Toftejorg MultiJet 50 with 2 nozzles

Connection	Turbine/ Inlet Guide	Nozzles (mm) (3/4" thread connection)	Article No.
Nipple: 2" Rp (BSP)	100%	2 x ø11	TE22M162
		2 x ø12	TE22M164
	0%	2 x ø12	TE22M168
		2 x ø13	TE22M180
		2 x ø14	TE22M182
		2 x ø15	TE22M184
Nipple: 2" NPT	100%	2 x ø11	TE22M112
		2 x ø12	TE22M114
	0%	2 x ø12	TE22M128
		2 x ø13	TE22M130
		2 x ø14	TE22M132
		2 x ø15	TE22M134

Standard configurations, Toftejorg MultiJet 50 with 4 nozzles

Connection	Turbine/ Inlet Guide	Nozzles (mm) (3/4" thread connection)	Article No.
Nipple: 2" Rp (BSP)	100%	4x ø8	TE22M040
		4x ø9	TE22M042
	0%	4x ø9	TE22M050
		4x ø10	TE22M052
Nipple: 2" NPT	100%	4x ø8	TE22M010
		4x ø9	TE22M012
	0%	4x ø9	TE22M030
		4x ø10	TE22M032

The machine is equipped with a clutch in the hub, which gives the possibility of rotation by hand the nozzles, when the machine is to be lifted out through a tank opening.

9.2 Available add-ons

TE22MXXX70:	ATEX/IECEX
-------------	------------

Explanation to Add-ons		
ATEX/IECEX		<p>ATEX/IECEX includes: ATEX/IECEX certified machine for use in explosive atmospheres. Category 1 for installation in zone 0/20 in accordance with directive 2014/34/EU.</p> <p>II 1G Ex h IIC 85°C...175°C Ga II 1D Ex h IIIC T85°C...T140°C Da</p>

10 Parts list and drawing, service kits and tools

10.1 MultiJet 50 with 2 nozzles

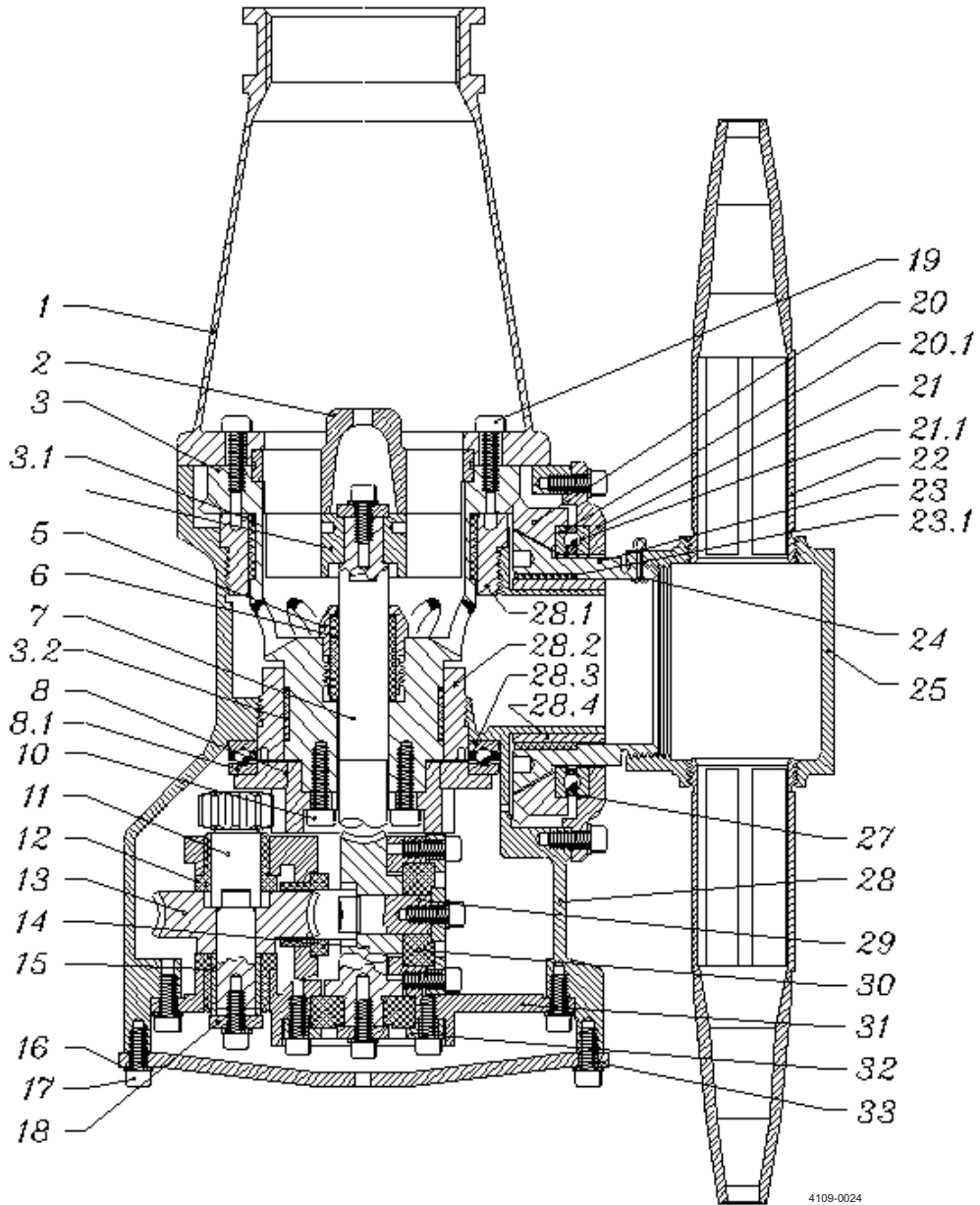

4109-0024

10 Parts list and drawing, service kits and tools

Parts list

Pos.	Qty	Denomination
1	1	Top Cone
2	1	Guide
3	1	Stem
3.1	1	Top Liner
3.2	1	Bottom Liner
4	1	Impeller
5	1	Gland
6	1	Main bush
7	1	Turbine shaft
8	1	Gear wheel w. ball race
8.1	1	Ball race
10	6	Screw
11	1	Pinion
12	3	Collar bush
13	1	Worm wheel w. reinforcem.
14	1	Worm wheel w. reinforcem.
15	1	Journal
16	21	Spring washer
17	29	Screw
18	4	Washer
19	8	Screw
20	1	Bevel gear w. ball race
20.1	1	Ball race
21	1	Hub cover
21.1	1	Ball race
22	2	Nozzle
23	1	Hub conical part
23.1	1	Hub liner
24	1	Cotter pin
25	1	Hub nozzle part
27	2	Ball retainer with balls
28	1	Body
28.1	1	Main collar upper
28.2	1	Main collar lower
28.3	1	Ball race
28.4	1	Hub collar
29	1	Horizontal shaft
30	2	Slide bearing
31	1	Gear frame
32	2	Bearing cover
33	1	Bottom cover

Service kits

Denomination	Item no.
◇ Minor service kit for MultiJet 50	TE55M000
● Major service kit for MultiJet 50	TE55M100

Configuration according to delivery note/order.

Parts marked with ◇ are included in the Minor Service Kit: TE55M000

Parts marked with ● are included in the Major Service Kit: TE55M010

The machine can be delivered with ATEX/IECEX certification.

See page 47 for more information on available add-ons.

Please refer to the Spare Part Manual for information on item numbers and materials. The Spare Part Manual is available from the online Alfa Laval product catalogue Anytime or the Close at hand spare part catalogue.

10 Parts list and drawing, service kits and tools

10.2 MultiJet 50 with 4 nozzles

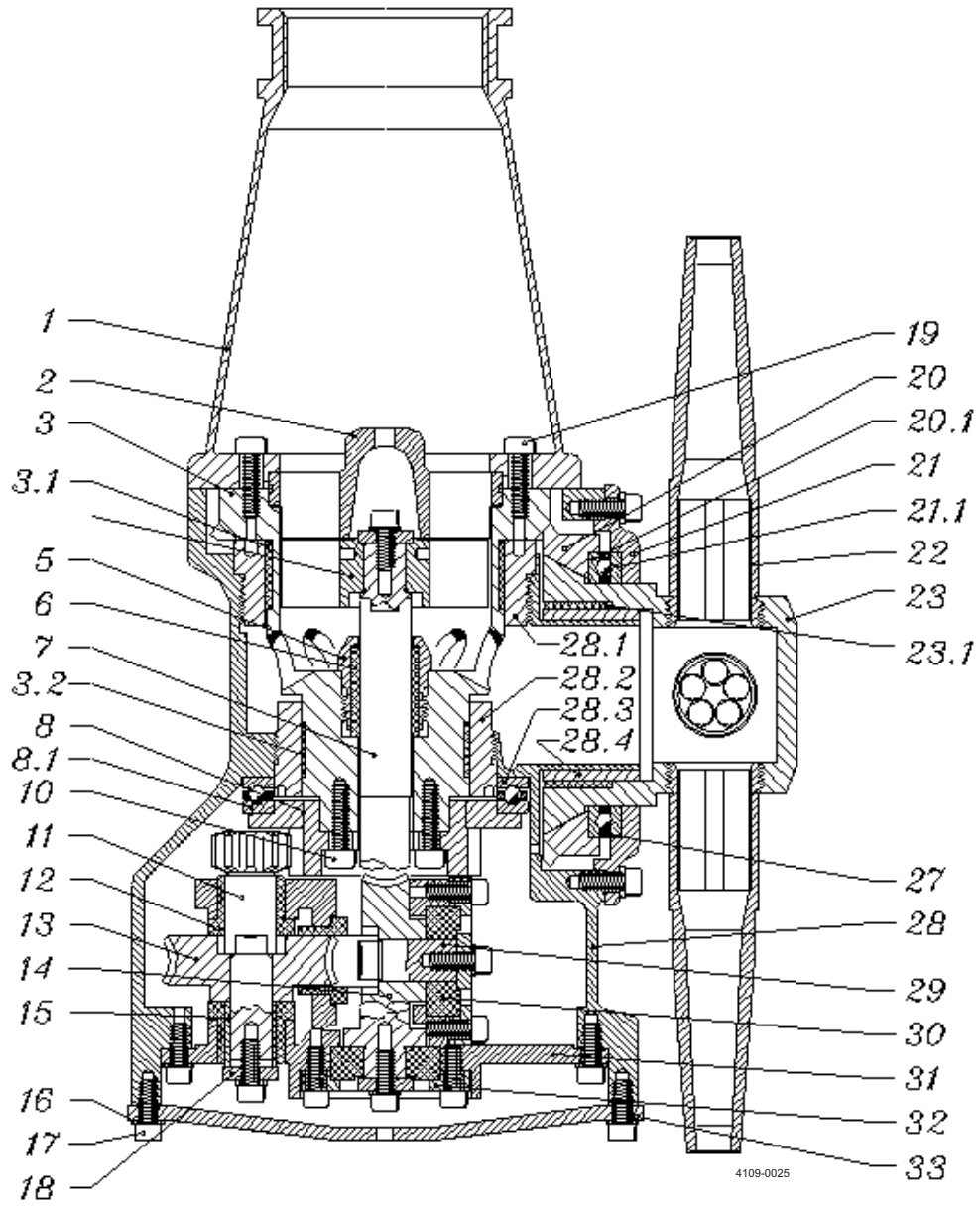

Parts list

Pos.	Qty	Denomination
1	1	Top Cone
	1	Top Cone
2	1	Guide
	1	Guide ring
3	1	Stem
3.1	1	Top Liner
3.2	1	Bottom Liner
4	1	Impeller
5	1	Gland
6	1	Main bush
7	1	Turbine shaft
8	1	Gear wheel w. ball race
8.1	1	Ball race
10	6	Screw
11	1	Pinion
12	3	Collar bush
13	1	Worm wheel w. reinforcem.
14	1	Worm wheel w. reinforcem.
15	1	Journal
16	21	Spring washer
17	29	Screw
18	4	Washer
19	8	Screw
20	1	Bevel gear w. ball race
20.1	1	Ball race
21	1	Hub cover
21.1	1	Ball race
22	4	Nozzle
	4	Nozzle
	4	Nozzle
23	1	Hub
23.1	1	Hub liner
27	2	Ball retainer with balls
28	1	Body
28.1	1	Main collar upper
28.2	1	Main collar lower
28.3	1	Ball race
28.4	1	Hub collar
29	1	Horizontal shaft
30	2	Slide bearing
31	1	Gear frame with bushes
32	2	Bearing cover
33	1	Bottom cover

Service kits

Denomination	Item no.
✧ Minor service kit for MultiJet 50	TE55M000
● Major service kit for MultiJet 50	TE55M100

Configuration according to delivery note/order.

Parts marked with ✧ are included in the Minor Service Kit: TE55M000

Parts marked with ● are included in the Major Service Kit: TE55M100

The machine can be delivered with ATEX/IECEx certification.

See page 47 for more information on available add-ons.

Please refer to the Spare Part Manual for information on item numbers and materials. The Spare Part Manual is available from the online Alfa Laval product catalogue Anytime or the Close at hand spare part catalogue.

10 Parts list and drawing, service kits and tools

10.3 Service intervals

Service Intervals

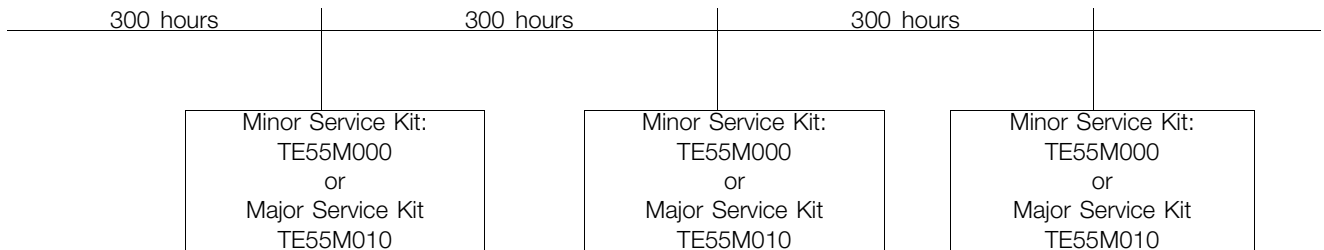

Please refer to the Spare Part Manual for information on item numbers and materials. The Spare Part Manual is available from the online Alfa Laval product catalogue Anytime or the Close at hand spare part catalogue.

10.4 Tools

Standard Tool kit for Toftejord MultiJet 50

Article no. TE81B080

Tool No.	Description	No.
TE134	Unbraco key for screw	1 pcs.
TE134A	Unbraco Screwdriver	1 pcs.
TE135	Unbraco key for screw	1 pcs.
TE135A	Unbraco screw driver	1 pcs.

Available on request:

Tool No.	Description
TE81B031	Pusher for 2" Gear frame
TE81B032	Fixture set f. Gear frame

Sketch of tools for replacement of Collars bush:

TE81B031: Pusher for Gear frame

TE81B032: Fixture set f. Gear frame

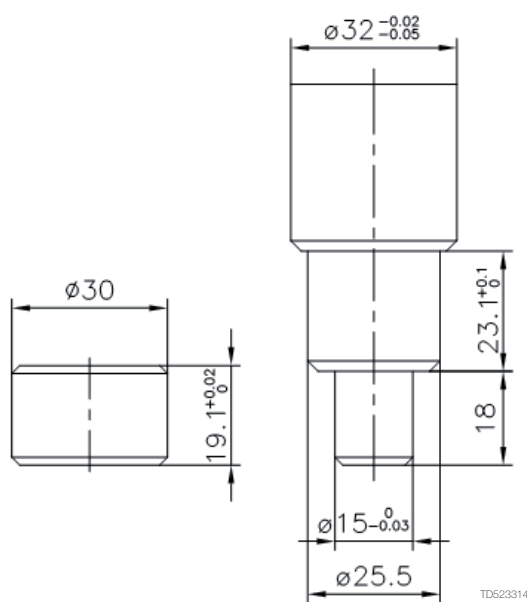
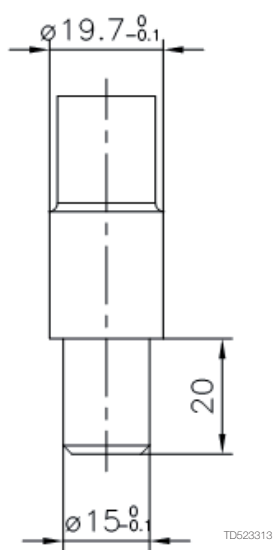

10 Parts list and drawing, service kits and tools

Sketch of tools for replacement of Main collars

A: TE81B131 - Tool for Upper collar

B: TE81B132: Tool for Lower collar

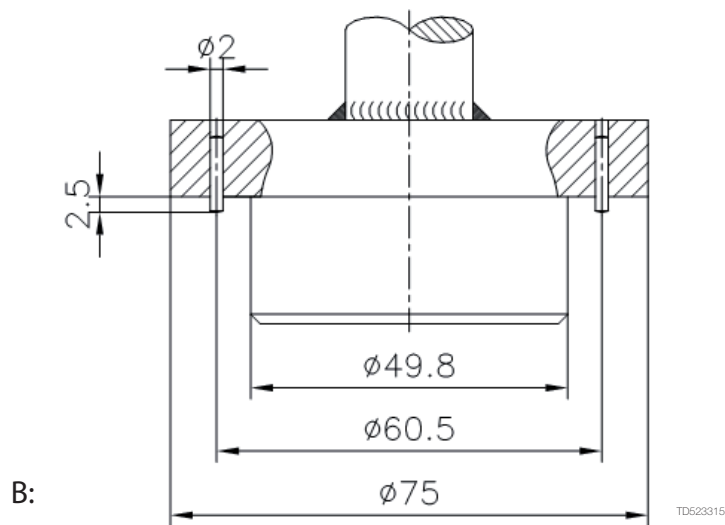
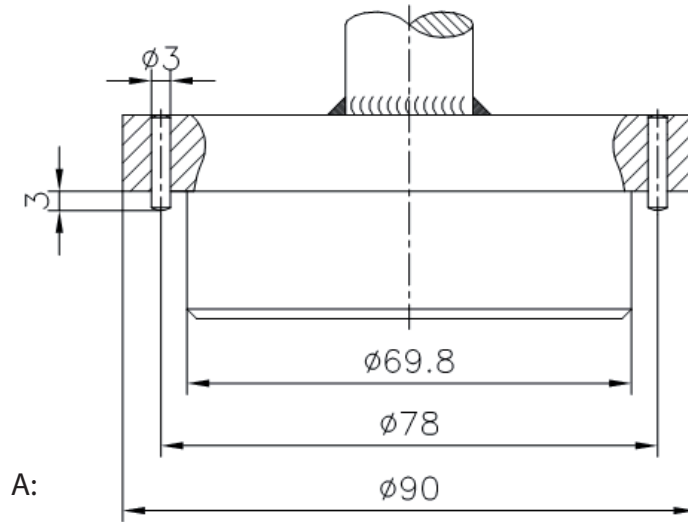

11.1 Service and repair

Upon every return of a product, no matter if for modifications or repair, it is necessary to contact your local Alfa Laval office to guarantee a quick execution of your request.

You will receive instructions regarding the return procedure from your local Alfa Laval office. Be sure to follow the instructions closely.

11.2 How to order spare parts

On the parts drawings as well as on all instruction drawings, the individual parts have a position number, which is the same on all drawings. From the position number, the part is easily identified in the parts lists, page 48 and 50.

Individual parts should always be ordered from the parts lists, page 48 and 50. Item number and denomination should be clearly stated.

Please refer to the Spare Part Manual for information on item numbers. The Spare Part manual is available from the on-line Alfa Laval Product catalogue Anytime or the Close at hand spare part catalogue.

Please also quote the type of machine and serial number. This will help us to help you. The type and serial numbers are stamped on the gear house of the tank cleaning machine.

11.3 How to contact Alfa Laval Kolding A/S

For further information please feel free to contact:

Alfa Laval Kolding A/S

31, Albuen - DK 6000 Kolding - Denmark

Registration number: 30938011

Tel switchboard: +45 79 32 22 00 - Fax switchboard: +45 79 32 25 80

www.toftejorg.com, www.alfalaval.dk - info.dk@alfalaval.com

Contact details for all countries are continually updated on our websites

How to contact Alfa Laval

Contact details for all countries are continually updated on our website.

Please visit www.alfalaval.com to access the information directly.

© Alfa Laval Corporate AB

This document and its contents is owned by Alfa Laval Corporate AB and protected by laws governing intellectual property and thereto related rights. It is the responsibility of the user of this document to comply with all applicable intellectual property laws. Without limiting any rights related to this document, no part of this document may be copied, reproduced or transmitted in any form or by any means (electronic, mechanical, photocopying, recording, or otherwise), or for any purpose, without the expressed permission of Alfa Laval Corporate AB. Alfa Laval Corporate AB will enforce its rights related to this document to the fullest extent of the law, including the seeking of criminal prosecution.