

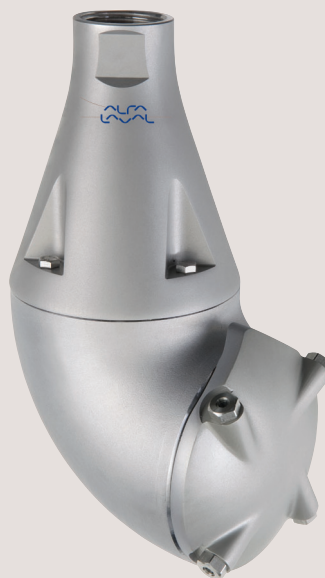

Instruction Manual

Alfa Laval Toftejorg™ MultiJet 25 Rotary Jet Head



Covering: Standard Machines
Machines delivered with ATEX/IECEX Certification in accordance with Directive 2014/34/EU
TE91A615. First published: 2007-06

ESE02750-EN7 2019-05

Original manual

The information herein is correct at the time of issue but may be subject to change without prior notice

1. EC/EU Declaration of Conformity	4
2. Safety	5
2.1. Important information	5
2.2. Warning signs	5
3. Introduction	6
3.1. Introduction	6
3.2. Intended use	6
3.3. Patents and trademarks	7
3.4. Marking	7
3.5. ATEX/IECEX marking	8
3.6. ATEX/IECEX temperature class and code	9
3.7. Quality system	9
4. Installation	10
4.1. General description	10
4.2. Functioning	10
4.3. General safety and installation instructions	12
4.4. Specific conditions for safe use in accordance with ATEX/IECEX certification	13
5. Operation	16
5.1. Normal operation	16
5.2. Safety precautions	17
6. Maintenance	18
6.1. Preventive maintenance	18
6.2. Service and repair of ATEX/IECEX certified machines	19
6.3. Maintenance intervals and service kits	19
6.4. General assembly/disassembly recommendations	21
6.5. Tools	21
6.6. Disassembly	22
6.7. Reassembly	24
6.8. Replacement of ball races	25
7. Trouble shooting guide	26
8. Technical data	27
8.1. Technical data	27
9. Product programme	31
9.1. Standard configurations	31
9.2. Available add-ons	31
9.3. Available welding connections	33
10. Parts list and drawing, service kits and tools	34
10.1. Alfa Laval Toftejorg MultiJet 25	34
10.2. Tools	36
11. General information	37
11.1. Service and Repair	37
11.2. How to Order Spare Parts	37
11.3. How to contact Alfa Laval Kolding A/S	37

1 EC/EU Declaration of Conformity

The Designated Company

Alfa Laval Kolding A/S

Company Name

Albuen 31, DK-6000 Kolding, Denmark

Address

+45 79 32 22 00

Phone No.

hereby declare that

Tank Cleaning Machine

Designation

Alfa Laval Toftejorg MultiJet 25

Type

From serial number 2018-0001 to 2030-99999

is in conformity with Machinery Directive 2006/42/EC and the following harmonized standard is used:
DS/EN ISO 12100:2011 Safety of Machinery - Risk Assessment

is in conformity with (Ex / ATEX) Directive 2014/34/EU and the following harmonized standards are used:
EN ISO 80079-36:2016, EN ISO 80079-37:2016, DS/EN ISO/IEC 80079-34:2011, Annex A, paragraph A.5.3 Rotating machines

EC Type Examination Certificate no. Baseefa04ATEX0358X and IECEX BAS 18.0067X

Marking:  II 1G Ex h IIC 85°C... 175°C Ga
II 1D Ex h IIC T85°C... T140°C Da

The QAN (Quality Assurance Notification) is carried out by SGS Fimko Oy, Särkiniementie 3, Helsinki 00211, Finland. Notified Body No. 0598.

EU Type Examination Certification is carried out by SGS Fimko Oy, Särkiniementie 3, Helsinki 00211, Finland. Notified Body no. 0598. IECEX Certificate of Conformity is carried out by Baseefa Ltd., Rockhead Business Park, Staden Lane, Buxton, Derbyshire SK17 9RZ, United Kingdom. IECEX Accepted Certification Body (ExCB).

The person authorised to compile the technical file is the signer of this document.

Global Product Quality Manager
Pumps, Valves, Fittings and Tank Equipment

Title

Lars Kruse Andersen

Name



Signature

Kolding

Place

2019-05-01

Date (YYYY-MM-DD)

This Declaration of Conformity replaces Declaration of Conformity dated 2016-07-01



MultiJet 25

Unsafe practices and other important information are emphasized in this manual.

Warnings are emphasized by means of special signs.

Always read the manual before using the tank cleaning machine!

2.1 Important information

WARNING

Indicates that special procedures must be followed to avoid serious personal injury.

CAUTION

Indicates that special procedures must be followed to avoid damage to the tank cleaning machine

NOTE

Indicates important information to simplify or clarify procedures.

2.2 Warning signs

General warning:



ATEX/IECEx warning:



3 Introduction

MultiJet 25

3.1 Introduction

Alfa Laval Toftejorg MultiJet 25 Rotary Jet Head has been developed to meet the highest demands for efficiency, reliability within industrial industry

This manual has been prepared as a guide for installing, operating and maintaining your Alfa Laval Toftejorg tank cleaning machine. Should you require further assistance, our Technical Sales Support department and worldwide net of sales offices are pleased to help you. Please quote the type, article and serial numbers with all of your enquiries; this helps us to help you. The type and serial number are placed on the body of the tank cleaning machine.

Get the best and most economical performance from your tank cleaning machine. Insufficient preventive maintenance means poor performance, unscheduled stops, shorter lifetime and extra costs. On the contrary, good preventive maintenance means good performance, no unscheduled stops and superior total economy

If the Alfa Laval Toftejorg MultiJet 25 stops rotating unintentionally within the warranty period, please return the machine to Alfa Laval. Please do not try to fix any mechanical problems before shipping.

Warning:



Before installing the machine and setting it into operation, carefully read the General safety and installation instructions (page 12) and the specific conditions for safe use in accordance with ATEX/IECEX Directive 2014/34/EU (page 13) and take all necessary precautions according to your application and local regulations.

NOTE

The illustrations and specifications contained in this manual were effective at the date of printing. However, as continuous improvements are our policy, we reserve the right to alter or modify any unit specification on any product without prior notice or any obligation.

The English version of the instruction manual is the original manual. We make reservations in regard to possible mistranslations in language versions of the instruction manual. In case of doubt, the English version of the instruction manual applies.

3.2 Intended use

The end-user should verify:

- that the tank cleaning machine is in conformity with respect to tank, vessel or container size in which it is used.
- that the construction materials (both metallic and non-metallic) are compatibility with product, flushing media, cleaning media, temperatures and pressure under the intended use.

The tank cleaning machine/rotary jet mixer is intended for use in closed tank, vessel or container. If used in open environment see 4.3 General safety and installation instructions.

To ensure the self cleanability and drainability the machine must be installed in vertical position.

3.3 Patents and trademarks

This Instruction Manual is published by Alfa Laval without any warranty. Improvements and changes to this Instruction Manual may at any time be made by Alfa Laval without prior notice. Such changes will, however, be incorporated in new editions of this Instruction Manual.

Alfa Laval Kolding A/S. All rights reserved.

The Alfa Laval logotype is a trademark or a registered trademark of Alfa Laval Corporate AB. "Toftejorg" is a trademark or registered trademark of Alfa Laval. The Alfa Laval Toftejorg™ MultiJet 25 product has patents in the EPO member states (EP 0 560 778), in the US (5333630) and in other countries and has a new patent pending (PCT/DK/2007/000062). Other products or company names mentioned herein may be the trademarks of their respective owners. Any rights not expressly granted herein are reserved.

3.4 Marking

Alfa Laval tank cleaning machines are all marked to allow for recognition of type of machine, machine name, serial number and manufacturing address. The marking is placed on the body of the tank cleaning machine.

Rotary Jet Head

MJ25

s/n.: yyyy-xxxxx

Alfa Laval, DK-6000 Kolding, Albuen 31



Serial number explanation

Machines supplied with or without standard documentation:

yyyy-xxxxx: serial number

yyyy: year

xxxxx: 5 digit sequential number

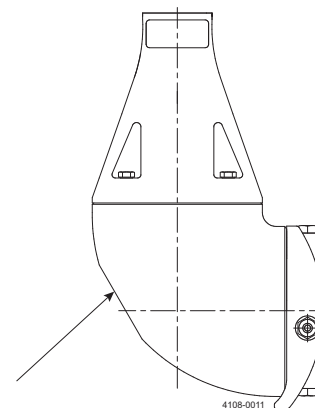

Marking area

3 Introduction

MultiJet 25

3.5 ATEX/IECEX marking

The Alfa Laval Toftejorg MultiJet 25 is certified as category I component. The ATEX certification is carried out by the Notified Body SGS Fimko Oy, who has issued the certificate no. Baseefa04ATEX0358X.

The IECEX certification is carried out by the Certification Body SGS Baseefa Ltd., who has issued the certificate no. IECEX BAS 18.0067X.

Note

Explosion protection type is constructional safety "c".

The marking on the ATEX/IECEX certified Alfa Laval Toftejorg MultiJet 25 is as follows (for information on marking position see section 3.4 Marking):

Rotary Jet Head
MJ25
s/n.: yyyy-xxxxx

Alfa Laval, DK-6000 Kolding, Albuen 31
II 1G Ex h IIC 85°C...175°C Ga
II 1D Ex h IIIC T85°C...T140°C Da
CE 0598 Baseefa 04ATEX0358X IECEX BAS 18.0067X

Serial number explanation:

Machines supplied with or without standard documentation:

yyyy-xxxxx: serial number

yyyy: year

xxxxx: 5 digit sequential number

3.6 ATEX/IECEx temperature class and code

The maximum surface temperature depends mainly on operating conditions which are the temperature of the cleaning fluid and the ambient temperature.

Group II EPL Ga

The gas temperature class is corrected with a safety margin of 80% due to a requirement for Group II EPL Ga equipment. The gas temperature class depends on the cleaning fluid temperature or the ambient temperature, whichever of the two is the highest.

Table for determining temperature class (gas atmospheres)		
Temperature Class	Cleaning fluid Temperature, T_p (°C)	Ambient temperature, T_{amb} (°C)
85°C (T6)	$\leq +68^\circ\text{C}$	$\leq +68^\circ\text{C}$
100°C (T5)	$\leq +80^\circ\text{C}$	$\leq +80^\circ\text{C}$
135°C (T4)	$\leq +108^\circ\text{C}$	$\leq +108^\circ\text{C}$
175°C	$\leq +140^\circ\text{C}$	$\leq +140^\circ\text{C}$

Group III EPL Da

The dust temperature class depends on the cleaning fluid temperature or the ambient temperature, whichever of the two is the highest. No dust layer is considered.

Table for determining temperature class (dust atmospheres)		
Temperature code	Cleaning fluid temperature, T_p (°C)	Ambient temperature, T_{amb} (°C)
T85°C	$\leq +85^\circ\text{C}$	$\leq +85^\circ\text{C}$
T100°C	$\leq +100^\circ\text{C}$	$\leq +100^\circ\text{C}$
T135°C	$\leq +135^\circ\text{C}$	$\leq +135^\circ\text{C}$
T140°C	$\leq +140^\circ\text{C}$	$\leq +140^\circ\text{C}$

Example of gas class determination

Cleaning fluid temperature is 67°C and ambient temperature is 75°C.
Gas class = T5

ATEX/IECEx marking on the equipment:



II 1G Ex h IIC 85°C...175°C Ga
II 1D Ex h IIC T85°C...T140°C Da

3.7 Quality system

The Alfa Laval Toftejorg MultiJet 25 is designed in accordance with the EHEDG design guidelines for sanitary design of processing equipment. It is produced according to Alfa Laval Kolding's ISO-9001 international Standard certified quality system. All parts are made from certified material and all non-metal parts are made from FDA compliant materials.

4 Installation

MultiJet 25

4.1 General description

The Alfa Laval Toftejorg tank cleaning machine is a media driven and media lubricated tank cleaning machine. No lubricating substances such as oil, grease etc. are used. All materials comply with FDA 21CFR§177 and for polymers also EU 10/2011. The machine is self-cleaning i.e. all internal and external surfaces are cleaned during normal operation.

For use in explosive hazard zones the ATEX/IECEX version can be used, provided it is installed according to safety instructions in local regulations.

4.2 Functioning

The flow of cleaning fluid into the machine passes through a turbine, which accordingly is set into rotation. Through a gear set and a driver tube, the turbine rotation is transmitted to the Cleaner Head.

The combined motion of the machine Body and the Nozzles ensures a fully indexed tank cleaning coverage. After $5 \frac{5}{8}$ revolutions of the Hub cover with Nozzles ($5 \frac{3}{8}$ revolutions of the machine Body), one coarse cleaning pattern is laid out on the tank surface and the first cycle has been made. During the following cycles, this pattern is repeated 7 times, each of which is displaced, and the pattern gradually becomes more dense. Finally, after 8 cycles - a total of 45 revolutions of the Hub Cover with Nozzles (43 revolutions of the machine Body), a complete cleaning pattern has been laid out, and the first pattern is repeated.

This is illustrated below for a spherical tank with the machine placed in the centre:

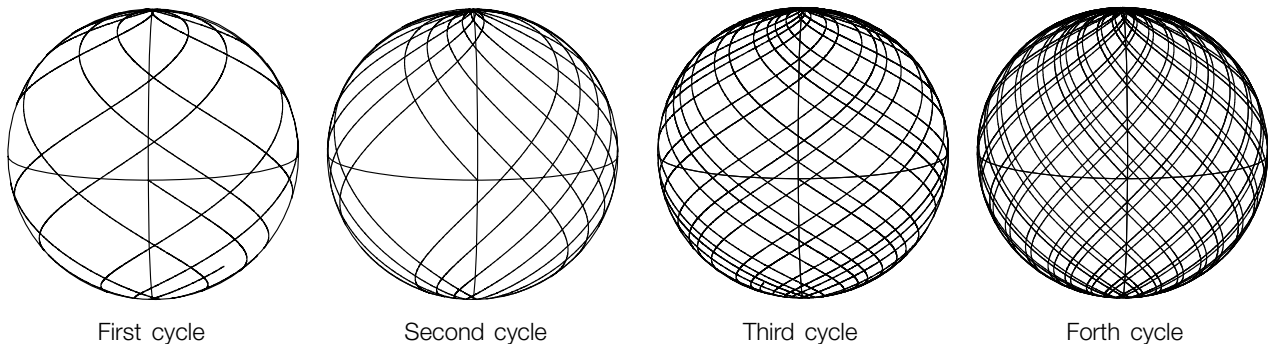

The number of cycles needed to perform a proper cleaning depends on type of soilage, position of the tank cleaning machine, cleaning procedure, cleaning temperature and cleaning agent.

For substances that are easily mobilised, i.e. are easy to remove, one cycle could be sufficient while in cases of more heavy soilage (high viscous, sticky substances, etc.) a more dense pattern/more cycles are needed.

The rotation speed of the turbine depends on the flow rate through the machine. The higher the flow rate, the higher the speed of rotation. In order to control the RPM of the machine for a wide range of flow rates, the machine has different turbines according to the Nozzle size.

Apart from the main flow flushing the gear and the Hub, and thereafter forming the jets through the Nozzles, fluid is flushed through all internal areas, through Bevel gear, Ball bearings and gaps between moving parts and finally also used for cleaning of the outside surfaces of the machine. The areas behind the Screws on the Cone are cleaned through small spray holes behind the Screws. In the bottom of the Body, a drainage hole is present to ensure self-draining. This self-draining is only ensured, if the machine is installed in upright position.

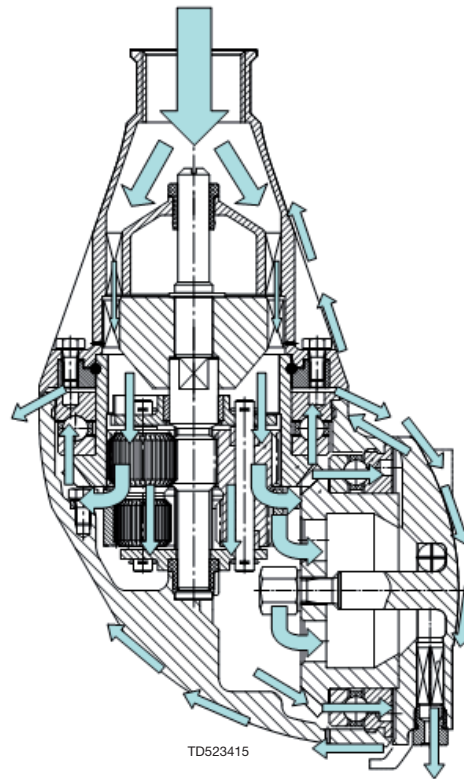

For all versions:

For devices with tapered thread connections to the down pipe, it is recommended that you secure the connection in a manner appropriate for the application. Subject to the intended use environment and any inhouse user requirements or policies, an adhesive such as Loctite No. 243 or equivalent could be used. Other methods could be acceptable and subject to customer preference.

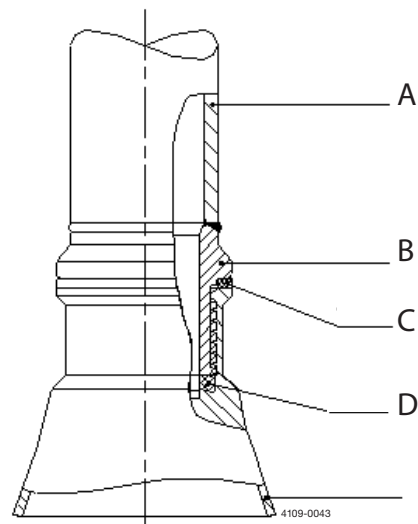

- A: Down pipe
- B: Welding adapter
- C: Seal PTFE
- D: Seal EPDM

4 Installation

MultiJet 25

4.3 General safety and installation instructions

The tank cleaning machine should be installed in vertical position (upright or upside down). It is recommended to install a filter in the supply line in order to avoid large particles, scale etc. to clog inside the machine. It is essential to avoid fine solid particles (e.g. fine sand) in cleaning fluid as they increase wear considerably.

In general, a filter with 3 mm holes is recommended in the supply line. In case of fine solid particles below 500 µm in the cleaning fluid, choose filter size accordingly.

In order to separate the CIP system from the process it is recommended to install a shutoff valve close to the machine inlet. This also prevents back-flow of liquid from the tank through the machine in case the cleaner head is submerged and there is an over-pressure inside the tank. The installation and operation shall be made in such a way that the self-draining of the machine is ensured.

It is recommended that the fluid valve fitted is of a type that **prevents hydraulic shocks**, which may cause severe damage to the Alfa Laval Toftejorg MultiJet 25 and/or the entire installation. Ideally, a frequency controlled pump with a ramp function for start-up is used for supplying the cleaning liquid.

Before connecting the machine onto the system, **all supply lines and valves should be flushed** in order to remove foreign particles.

The machine should be screwed tightly onto its supporting supply line using a 36 mm flat jawed spanner (tool No. TE81B040) on the flats machined on the inlet Cone.

During handling and installation handle the machine with care in order not to damage the surface finishes of the machine.

The Alfa Laval Toftejorg MultiJet 25 machine has been tested at the factory before shipping. You can check that the machine is in operating condition by blowing compressed air into the inlet, while holding the machine by the cone and verify that the rest of the machine rotates evenly. If resistance is recognised, the machine should be disassembled in order to localise the cause or returned to the nearest Alfa Laval Service Centre.

Upon arrival check that the machine is in operation condition by inserting a flathead Screwdriver in top of turbine shaft and easily turn Turbine shaft anti-clockwise. If any resistance is recognised, the machine should be disassembled in order to localise the cause.

For devices with tapered thread connections to the down pipe, it is recommended that you secure the connection in a manner appropriate for the application. Subject to the intended use environment and any inhouse user requirements or policies, an adhesive such as Loctite No. 243 or equivalent could be used. Other methods could be acceptable and subject to customer preference.

NOTE

Do not try to turn the nozzle head by hand, since this may damage the Gear. The Nozzle head can be turned by blowing compressed air through the inlet connection.

NOTE

The machine shall be installed in accordance with national regulations for safety and other relevant regulations and standards. In EU-countries the complete system must fulfil the EU-machine Directive and depending of application, the EU-Pressure Equipment Directive, the EU-ATEX/IECEx Directive and other relevant Directives and shall be CE-marked before it is set into operation.

Warning:



Precautions shall be made to prevent starting of the cleaning/mixing operation, while personnel are inside the tank or otherwise can be hit by jets from the nozzles.

For information on use in potential explosive atmospheres see paragraph 4.4 Specific conditions for safe use in accordance with ATEX/IECEx certification page 13.

4.4 Specific conditions for safe use in accordance with ATEX/IECEx certification

Directive 2014/34/EU

NOTE

Explosion protection type is constructional safety “c”.

Warning: Operated in a hazardous area



The unit may be operated in a hazardous area only when completely filled with cleaning fluid/steam. If a medium other than the cleaning fluid/steam is passed through the equipment the flow must not be high enough to cause the equipment to operate.

Warning: Operating guidance



The unit shall be operated in line with guidance provided by IEC/TS 60079-32-1 for tank cleaning.

Warning: Temperature class and ambient temperature range



The maximum surface temperature depends mainly on operations conditions which is the temperature of the cleaning fluid and ambient temperature. The temperature class and ambient temperature range are shown in paragraph 3.6 ATEX/IECEx temperature class and code, page 9.

Warning: Max. permitted temperature



When working:
The maximum permitted cleaning fluid temperature and ambient temperature is 95°C.
When not working:
The maximum permitted ambient temperature is 140°C.

Warning: Draining using compressed air



Draining using compressed air must not be done in ex classified zone.
Draining using compressed air is possible in non ex classified zones (see page 16).

Warning: Earthing



All metal and other conductive or dissipative material should be connected to earth with the exception of very small items.
For further information see IEC/TS 60079-32-1:2013 Explosive atmospheres – Part 32-1: Electrostatic hazards, guidance. With focus on clause 6.2.3, 7.2.1, 7.3, 7.9.2, 13.

Warning: Earthed when in use



The unit must be effectively earthed at all times when in use.

4 Installation

MultiJet 25

4.4 Specific conditions for safe use in accordance with ATEX/IECEx certification

Warning: Max. permitted steaming temperature

The maximum permitted steam temperature through the machine and ambient temperature is 140°C.



Warning: Steaming tanks larger than 100 m³

Tanks with capacities larger than 100 m³ that could contain a flammable atmosphere should not be steam cleaned, as steam cleaning tanks produces an electrostatically charged mist. Tanks smaller than 100 m³ may be steam cleaned.

For further information see IEC/TS 60079-32-1:2013 Explosive atmospheres – Part 32-1: Electrostatic hazards, guidance. With focus on clause 7.10 and 8.5.



Tank size information

The tank cleaning machine has been certified by accredited notified body and can operate in tanks having an enclosed volume up to 100 m³ as long as all ATEX/IECEx warnings in the instruction manual are complied with.

General guidelines for tanks larger than 100 m³:

Tanks larger than 100 m³ must not be steam cleaned – See guide IEC/TS 60079-32-1:2013 clause 7.10.5 and 8.5

To use the unit in tanks larger than 100m³ is possible under certain conditions.

It is necessary to know the current factors such as tank size, cleaning solvent and product.

Additives can be used in the cleaning solvent, or, for example, the tank can be filled with nitrogen. The basic guidelines are described in the guide IEC/TS 60079-32-1:2013.

It must be ensured that the equipollently bonding of all conductive metal objects is in accordance with national regulations for use.

The cleaning fluid conductivity must correspond to the products in the group “High conductivity”, cf. IEC/TS 60079-32-1:2013 clause 7.1 and 7.2.

High conductivity	> 10 000 pS/m
Medium conductivity	between 25 × εr pS/m and 10 000 pS/m
Low conductivity	< 25 × εr pS/m

For liquids with a dielectric constant of around 2, (e.g. hydrocarbons), these classifications reduce to:

High conductivity	> 10 000 pS/m
Medium conductivity	between 50 pS/m and 10 000 pS/m
Low conductivity	< 50 pS/m

Following a guidance document such as IEC/TS 60079-32-1:2013 to establish safe use of machinery and process is the users own responsibility and is not covered by the ATEX/IECEx certification for this unit except for tanks up to 100 m³. For further information see IEC/TS 60079-32-1:2013 Explosive atmospheres – Part 32-1: Electrostatic hazards, guidance with focus on clause 7.1.3, 7.1.4, 7.2.1, 7.2.4.

4.4 Specific conditions for safe use in accordance with ATEX/IECEx certification

Warning: Process generated electrostatic



The user must address the electrostatic hazards generated from the process of the equipment in accordance with guidance document IEC/TS 60079-32-1:2013.

Warning: Electrostatically charged liquid



Liquids can become electrostatically charged when they move relative to contacting solids or the spraying of liquids can also create a highly charged mist or spray. The liquid must be made electrically conductive by additives or otherwise.

For further information see IEC/TS 60079-32-1:2013 Explosive atmospheres – Part 32-1: Electrostatic hazards, guidance. With focus on clause 7.1.3, 7.1.4, 7.2.1, 7.2.4.

Warning: Appropriate cleaning fluid



The cleaning fluid should be appropriate for the application (e.g. so no chemical reaction can take place between the cleaning fluid and the residue of process fluid/powder/compound which can generate heat or a hybrid mixture).

Chemical reactions in Zone 20 - Hybrid mixtures:

End-user must ensure that the cleaning fluid used does not create a hybrid mixture according to IEC 60079-10-1:2015 Annex I.1 in connection with powder / dust residues in the tank in zone 20.

This should ensure that the atmosphere does not change to a classification that lies outside the machine's certified scope. When the machine is used for cleaning tanks containing potentially flammable dust atmospheres, and a potentially flammable fluid is used as the cleaning fluid then an assessment of the hybrid mixture shall be undertaken by the user, prior to operation.

For further information see IEC 60079-10-1:2015 Explosive atmospheres – Part 10-1: Classification of areas – Explosive gas atmospheres. With focus on clause 3.6.6 and Annex I – Hybrid mixtures.

Warning: Fluid pressure



The maximum permitted cleaning fluid pressure is 8 bar.

In addition to the above mentioned precautions relating to Directive 2014/34/EU, the Safety Precautions on page 12 must be observed.

5 Operation

MultiJet 25

5.1 Normal operation

Cleaning Media

Use only media compatible with Stainless Steel AISI 316L, SAF 2205, PVDF or PEEK, PFA HP and EPDM. Normal detergents, moderate solutions of acids and alkalis are acceptable. Aggressive chemicals excessive concentrations of chemicals at elevated temperatures, as well as certain hypochlorides should be avoided. If in doubt, contact your local Alfa Laval sales office.

NOTE

Do not try to turn the hub with nozzles by hand, since this may damage the gear. The hub with nozzles can be turned by blowing compressed air through the inlet connection or by using a socket wrench on top of the turbine shaft.

PEEK is not resistant to concentrated sulphuric acid.

Product

In cases where the machine is submerged in, or in other ways exposed to, product the compatibility between stainless steel AISI 316L, SAF 2205, PVDF or PEEK, PFA and EPDM and the product must be considered carefully.

NOTE

EPDM swells significantly exposed to fatty materials.

Pressure

Avoid hydraulic shocks. Increase pressure gradually. Do not exceed 8 bar inlet pressure. Recommended inlet pressure: 5-7 bar. High pressure in combination with high flow rate increase consumption of wear parts. High pressure also reduces the cleaning effect.

Draining using compressed air

If the machine is drained using compressed air, then the compressed air pressure must not cause the machine body rotation to exceed 4.5 rpm (corresponding to approx. 13 sec. per rev of the body) in order to avoid risk of machine breakdown.

Draining should always be done inside the tank.

See paragraph 4.4 Specific conditions for safe use in accordance with ATEX/IECEx certification (page 13).

Steam cleaning

If steam cleaning is done through the machine, the steam pressure must not cause the machine body rotation to exceed 12 rpm (corresponding to approx. 5 sec. per rev of the body) in order to avoid risk of machine breakdown. See paragraph 4.4 Specific conditions for safe use in accordance with ATEX/IECEx certification (page 13).

Temperature

The maximum recommended cleaning fluid is 95°C. The maximum recommended steam temperature is 140°C. The maximum ambient temperature is 140°C.

See paragraph 4.4 Specific conditions for safe use in accordance with ATEX/IECEx certification (page 13).

After use cleaning

After use flush the machine with fresh water. Cleaning media should never allow to dry or settle in the system due to possible "salting out" or "scaling" of the cleaning media. If cleaning media contains volatile chloride solvents, it is recommended **not to flush with water** after use, as this might create hydrochloric acid.

5.2 Safety precautions

The machine is intended for use inside a tank only. As peak velocity of main jets reaches 40 m/sec., The Alfa Laval Toftejorg MultiJet 25 must not be operated in open air or when tank is open.

Warning:



Hot chemicals and steam under pressure may be used for cleaning and sterilising. Protect against scalding and burning. Never tamper with or try to open clamps or other connections while system is in operation. Make sure that system is depressurised and drained before disassembly.

The cleaning jets impinging the tank surface are a source of noise. Depending on pressure and distance to the tank walls, noise level may reach up to 85 dB.

Warning:



Tanks may contain poisonous/hazardous products or products which represent an environmental or safety risk. Never open tank and dismount the machine without checking previous tank contents and necessary precautions.

See also 3.6 ATEX/IECEx temperature class and code, page 9.

6 Maintenance

MultiJet 25

6.1 Preventive maintenance

Following the Alfa Laval Preventive Maintenance Guidelines and using the Alfa Laval Service Kits ensures the availability of your equipment at all times and enables you to plan your operating budget and your downtime. The risk of unscheduled breakdowns due to component failure is virtually eliminated and in the long term your operating costs are reduced.

Alfa Laval Tank Cleaning Equipment Service Kits contain all you need. They comprise genuine Alfa Laval spare parts, manufactured to the original specifications.

The recommended preventive maintenance program is based on tank cleaning machines working in average conditions. However, a tank cleaning machine, exposed to heavy soiling and recirculation CIP liquid containing abrasives and/or particulates, needs more frequent attention than one exposed to light/no soiling and recirculation with ordinary CIP liquid. Alfa Laval Kolding A/S recommends you to adjust the maintenance program to suit the cleaning task in hand. Contact your local Alfa Laval sales office for discussion

For further information regarding Alfa Laval Service Kits and service intervals, see paragraph 6.3 Maintenance intervals and service kits on page 19 of this manual or the Spare Parts Manual.

NOTE

Handle the Alfa Laval Toftejorg MultiJet 25 with care. Take proper action to protect surfaces from being damaged. Always use only proper tools and the Alfa Laval Toftejorg MultiJet 25 standard tool kit (page 21). Never use force, hammer or pry components together or apart. Always perform all assembly/disassembly steps in the order described in this manual. Clean all surfaces prior to assembling. Especially take care of the mating surfaces. Work in a clear well-lighted work area.

According to "Regulation (EC) No 1935/2004 - Article 17" effective from 27th of October 2006, producers of food shall ensure traceability of the materials and articles intended to come into contact with foodstuffs. It is recommended that a traceability system is setup for replacement of wear parts and spare parts. This makes it possible to identify into which machine a given wear part or spare part has been inserted.
--

6.2 Service and repair of ATEX/IECEX certified machines

Warning:



All service and repair of ATEX/IECEX certified machines can be performed by Alfa Laval Kolding A/S, Denmark, or by an Alfa Laval service center approved by Alfa Laval Kolding A/S.

Changes to the machine are not allowed without approval by the person responsible for the ATEX/IECEX certification at Alfa Laval. If changes are made – or spare parts other than Alfa Laval original spare parts are used - the EC Type Examination certification (the ATEX/IECEX Directive) is no longer valid.

In order to ensure compliance with the ATEX/IECEX regulations and keep the machine ATEX/IECEX certification valid, the service or repair must be performed by an authorized person with knowledge of the ATEX/IECEX requirements and regulations. All spare parts must be original Alfa Laval spare parts and the repair or service must be done according to the instructions in this manual.

If a customer wishes to carry out service or repair himself, it is the responsibility of the repair shop to ensure that the ATEX/IECEX requirements are met in any way possible. After performing service or repair, the repair shop thus carries the full responsibility for traceability of all relevant documents in order to ensuring the retention of the ATEX/IECEX certification of the machine.

6.3 Maintenance intervals and service kits

It is recommended that the wear parts are check every 500 working hours for machine working under normal conditions. There is a Minor and a Major service kit for the Alfa Laval Toftejorg MultiJet 25 (see the following pages).

Service intervals

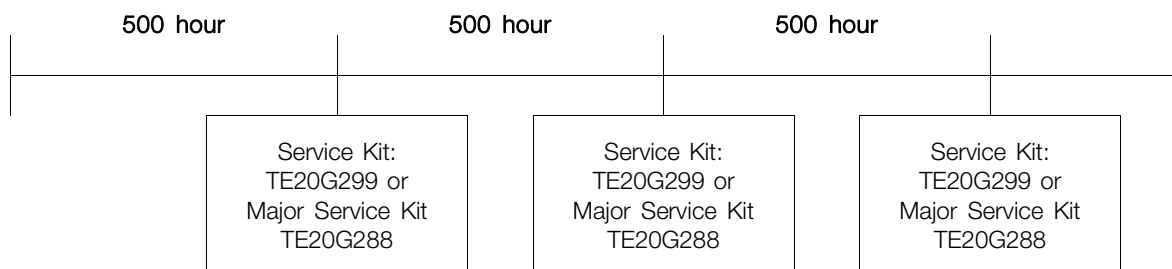

Every 500 working hours

1. Disassemble machine as described on the following pages.
2. Clean material build-up and deposits from internal parts with Scotch-brite, S-Ultra-fine, eventually chemical media and fine abrasive cloth.
3. Check Slide bearing (14) for wear. If end face of Slide bearing is worn more than 1 mm into Slide bearing, it should be replaced.
4. Check bearing for Turbine shaft top (24)) in Cone and Body. If holes are worn oval to a max. diameter of more than 10.4 mm, Bearings should be replaced. Thickness of collar is to be min. 3.5 mm for Bearing in Body. If the Bearings are loose in a horizontal direction, the bearings should be replaced.
5. Check Carrier bearing (15.3). If worn oval to a max. diameter of more than 15.8 mm, it should be replaced.

6 Maintenance

MultiJet 25

The items (#) refer to section **10 Parts list and drawing, service kits and tools** and illustrations in section **6.6 Disassembly**

NOTE

Timely replacement of Slide bearings and bearings for Turbine shaft prevents costly damage to the gearbox.

6. Check Planet wheels (15.4 and 15.5) while still mounted in planet gear carrier (15.6). They must rotate easily on Shafts. If restriction or much clearance on Shafts is felt, Planet wheels should be dismantled for inspection of bearing bushes and Shafts for Planet wheel (15.2). Max diameter of holes: 6.2 mm. Check tooth wear. **If replacement is necessary, Planet wheels must be replaced as a pair.**
7. Check unrestricted rotation of Ball bearings. Inspect for build-up of foreign material on Stem nut (9) and Hub nut (18), in Ball retainers (10) and Ball races.
8. Inspect the nozzle vanes for foreign objects (e.g. product pulp, threads, etc.) and if necessary clean with care – damaging nozzles (or fouled nozzles) will decrease the throw length of the machine. Clean using compressed air or tweezers.
9. Replace washer (22)
10. Assemble machines as described in the following pages.
11. Check that the machine is in operating condition by inserting flathead Screwdriver in top of Turbine shaft, and easily turn Turbine shaft anti-clockwise. If any resistance is recognised, the machine should be disassembled in order to localise the cause.
12. If Ball races (16.2 and 17.2) on Stem and Hub as well as Stem/Hub nut w. Ball race (9 and 18) and Washer (22) are heavily worn, they should be replaced. Also the Ball retainer w. balls (10) should be replaced if heavily worn.

Apart from the parts specifically mentioned above, all the remaining wear parts should regularly be inspected for wear. Which parts that are wear parts appear from the Spare Part Manual, available from the on-line Alfa Laval product catalogue Anytime or the Close at hand spare part catalogue.

MultiJet 25

The items (#) refer to section **10 Parts list and drawing, service kits and tools** and illustrations in section **6.6 Disassembly**

6.4 General assembly/disassembly recommendations

- Always read the instruction and maintenance manuals carefully before service.
- Always replace all parts included in the Service Kit.
- Prior to assembly/disassembly clean all tools and fixtures to ensure that scratches and marks and trace of soil/corrosion from tools are avoided.
- Do not scratch or damage the surfaces of the machine.
 - Always place components on soft material

Check surfaces for product residues and clean all parts before assembly. Assembly of the machine is described on the following pages.

6.5 Tools

Disassembly Tools needed for Maintenance and Repair

(For tool kit see page 36).

Besides the standard toolkit for the Alfa Laval Toftejorg MultiJet 25 and the Torque wrench toolkit, additional tools are needed:

- Flathead screwdriver (size 5/32")
 - Slip joint pliers
 - Rubber hammer
 - Drift punch (size $\varnothing 5$ mm)
 - Bench vice (large enough to secure the body of the MultiJet 25)
 - 11 mm open ended spanner
 - Support ring (only for changing Ball races) - e.g. a piece of pipe with an inner diameter of $\varnothing 84$
-

6 Maintenance

MultiJet 25

The items (#) refer to section 10 Parts list and drawing, service kits and tools and illustrations in section 6.6 Disassembly

6.6 Disassembly

1. Remove the 4 Screws (8) using a socket wrench (tool No. TE462A).
2. Lift off Cone (1).
3. Withdraw Turbine shaft (2) with Impeller. If necessary, turn Turbine shaft left and right.
4. Remove Circlip (4) using a flathead Screwdriver and pull off Impeller (5).
5. Withdraw Carrier assembly (15) while turning/rocking carrier left and right.
6. Remove Cotter pins (15.7) using a slip joint plier, pull out Shafts (15.2) and remove Planet wheels (15.4 and 15.5). If necessary, push out Carrier bearing (15.3)
7. If necessary, push out Bearing for Turbine shaft top (24) from Cone (1) using tool no. TE462A.

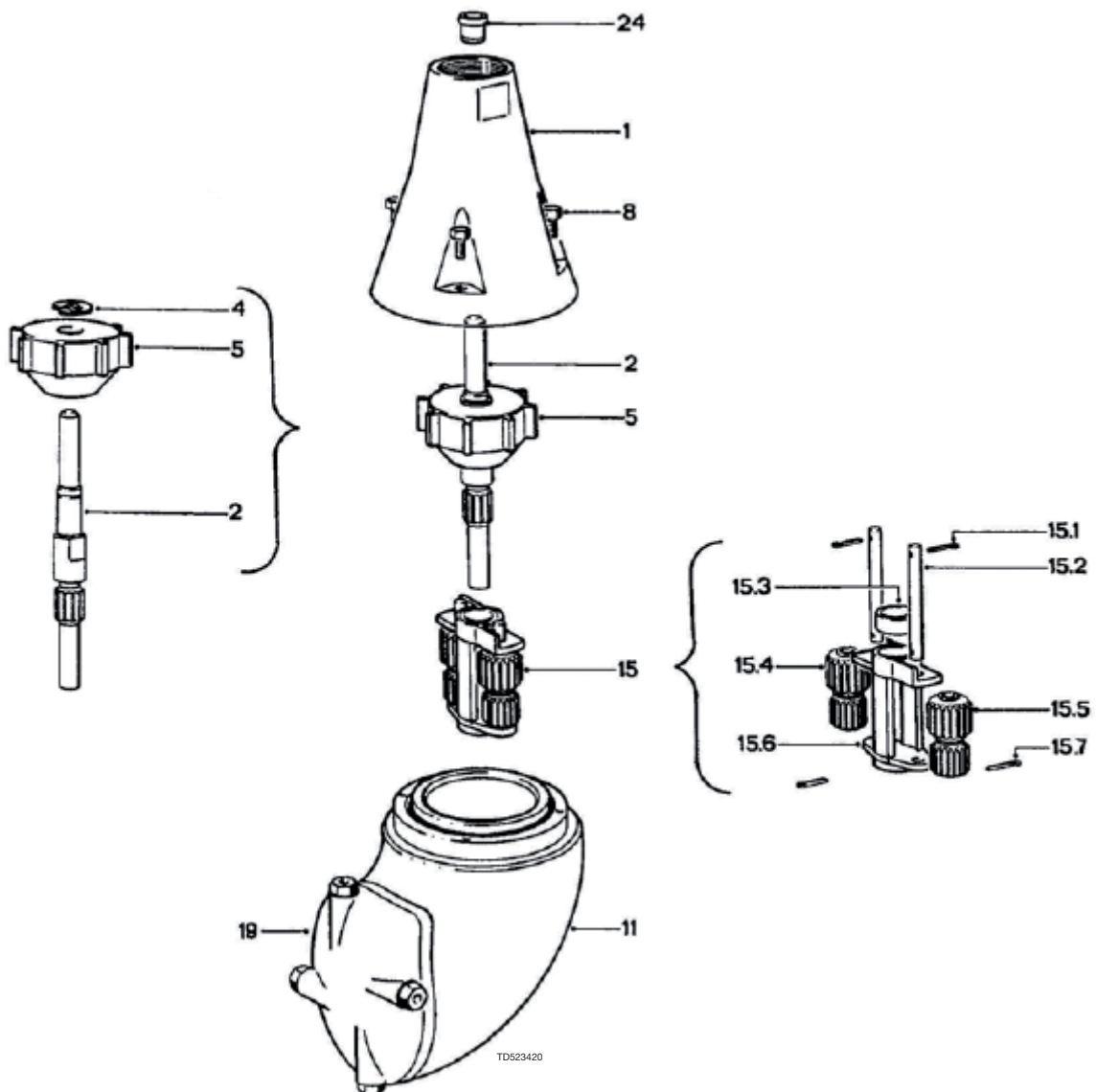

8. Remove Retainer spring (6). Use flathead Screwdriver to lift Retainer spring out of groove in Stem (16). Lift off Retaining ring (7).
9. Hold Body against table and unscrew Stem nut w. ball race (9) with Caliper (tool No. TE369) – see page 21. If the Stem Nut with Ball Race is difficult to loosen use rubber hammer on Caliper. Withdraw Stem (16) together with Ball retainer w. balls (10).
10. Remove the 3 Screws (12) with a socket wrench (tool No. TE462A) and draw out Internal gear (13).

MultiJet 25

The items (#) refer to section 10 Parts list and drawing, service kits and tools and illustrations in section 6.6 Disassembly

- 11. Secure the body in Bench vice (NB!!: use cloth between jaws and body to avoid making scratches and imperfections in body surface) so that the hub cover is secured. Insert a 13 mm spanner (tool No. TE81B041) onto cap nut (23) and unscrew the Cap nut (23). Remove Washer (22). IMPORTANT: Inserting drift punch into nozzle (21), instead of using the bench vice, to apply resistance for unscrewing Cap nut (23), damages the nozzle and the nozzle vane.
- 12. Hold Body against table and unscrew Hub nut w. ball race (18) with Caliper (tool No. TE369) – see drawing below. If the Stem nut w. Ball race is difficult to loosen use rubber hammer on Caliper.

NOTE

Left-hand thread

Withdraw Hub (17) together with Ball retainer w. balls (10).

- 13. With flathead screwdriver lift Slide bearing (14) and Bearing for Turbine shaft bottom (3) out of Body – see drawing below.
- 14. Unscrew Nozzles (21) with 11 mm spanner. Be careful not to damage Nozzle vanes (20) as this will severely reduce Nozzle performance. Nozzle vanes should not be removed unless they need to be replaced.

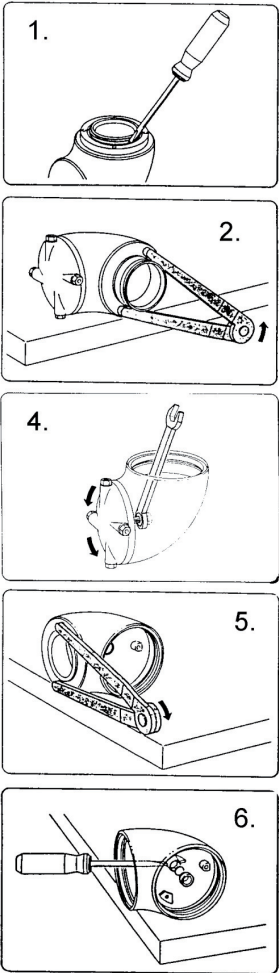
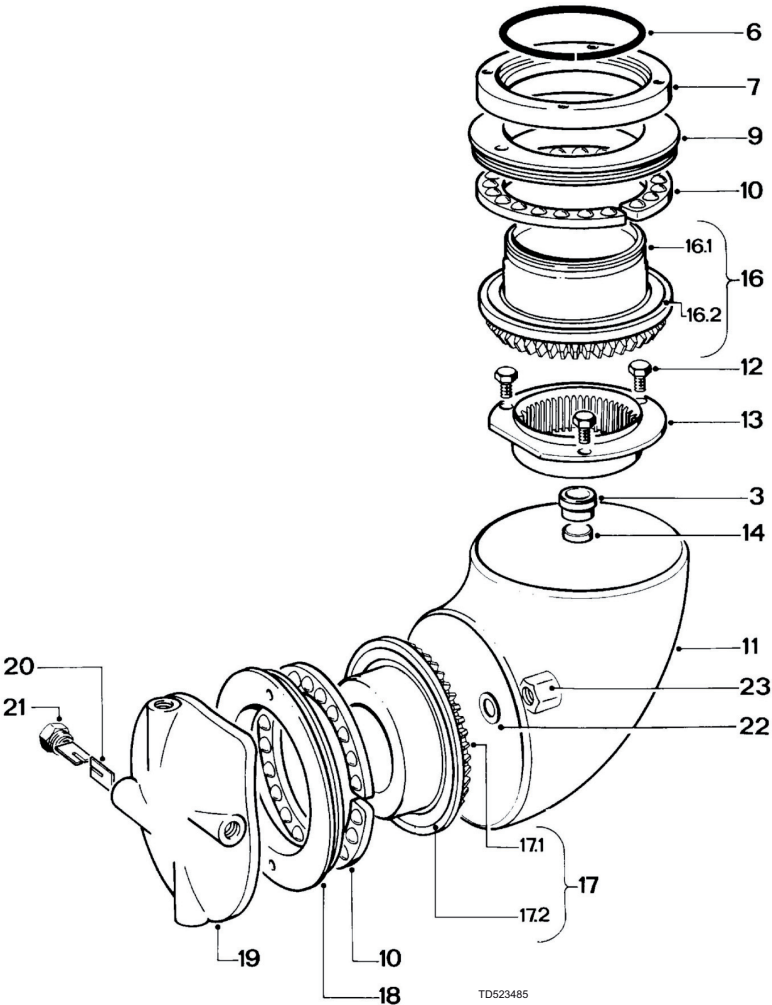

6 Maintenance

MultiJet 25

The items (#) refer to section 10 Parts list and drawing, service kits and tools and illustrations in section 6.6 Disassembly

6.7 Reassembly

Before reassembly, make sure that all parts are clean without deposits or build-up of foreign matter.

Inspect the nozzle vanes for foreign objects (e.g. product pulp, threads, etc.) and if necessary clean with care – damaging nozzles (or fouled nozzles) will decrease the throw length of the machine. Clean using compressed air or tweezers.

1. Insert Bearing for Turbine shaft top (24) in top of Cone (1). (Use drift punch to align and make the initial pressure-by-hand into the hole for the bearing. Then push it all the way in using the reverse end of the socket wrench (if needed use rubber hammer to apply pressure).

NOTE

The two Planet wheels are different: on Planet wheel 1, teeth of upper and lower gearing are aligned, while they are displaced ½ tooth on Planet wheel 2.

2. Insert Carrier bearing (15.3) and push with thumb. Insert Planet wheels (15.4 and 15.5) and Shafts (15.2) and secure with Cotter pins (15.7) – lock the Cotter pins by bending the ends around the Shafts (15.2). Check free rotation of Planet wheels.
3. Insert Carrier Assembly (15), into Body: Hold Body in one hand and use the other to turn Hub Cover (19) left and right with small rocking movements until carrier falls through Internal gear (13). Check that carrier is fully home on Bearing for Turbine shaft bottom (3) in Body: Rotate Carrier Assembly by hand a few rotations to check correct position and function. (Hub cover (19) is now locked and can only rotate by moving the Carrier assembly).
4. Mount Impeller (5) on Turbine shaft (2) and secure with Circlip (4) using flathead Screwdriver.
5. Insert Turbine shaft with Impeller through Carrier Assembly. Rotate Impeller to ensure correct insertion into Bearing for Turbine shaft (3) in Body. Check unrestricted rotation.
6. Mount Cone (1) over Turbine shaft and Retaining ring. Mount and tighten the 4 Screws (8) with Socket wrench (tool No. TE462A).
7. Place Slide bearing (14) in Body and push in Bearing for Turbine shaft (3) with thumb (or end of Socket Wrench). Make sure that Bearing is fully home.
8. Insert Hub (17) together with Ball retainer w. balls (10). Mount Hub nut w. Ball race (18) with Caliper (tool No. TE369) and tighten. The Hub nut w. Ball race should be tightened so much that it cannot be loosened by hand (e.g. use rubber hammer a few times on Caliper to increase torque). **Note: Left-hand thread.**
9. Insert Hub cover (19) into centre hole of Hub (17).
10. Place Washer (22) on threaded pin on Hub cover (19) and mount Cap nut (23). Insert spanner (tool No. TE81B041) into Body, hold Cap Nut (23) and by hand screw on Hub cover (19) and tighten to a torque of 25 Nm using torque wrench toolkit (tool. No. TE81087). Check free rotation of Hub.

Warning:



Tightening torque: 25 Nm
Use torque tool kit or alike

11. Insert Internal gear (13), mount Screws (12) and tighten with Socket wrench (tool No. TE462A).
12. Insert Stem (16) together with Ball retainer w. balls (10). Mount Stem nut w. ball race (9) with Caliper (tool No. TE369) and tighten. Turn Hub cover (19) and check unrestricted rotation.
13. Place Retaining ring (7) over Stem (16) and push on Retainer spring (6) and "click" into groove in Stem. Check free rotation.

MultiJet 25

The items (#) refer to section 10 *Parts list and drawing, service kits and tools* and illustrations in section 6.6 *Disassembly*

6.8 Replacement of ball races

1. Place Stem or Hub completely (16 or 17) in a support ring (e.g. a piece of pipe with an inner diameter of $\varnothing 84$) and press off Ball race. Press parallel. Be careful not to damage teeth and opposite end face of Stem.
2. With the support ring (e.g. a piece of pipe with an inner diameter of $\varnothing 84$) press Ball race fully home. Press parallel. Be careful not to damage surface of Ball race.

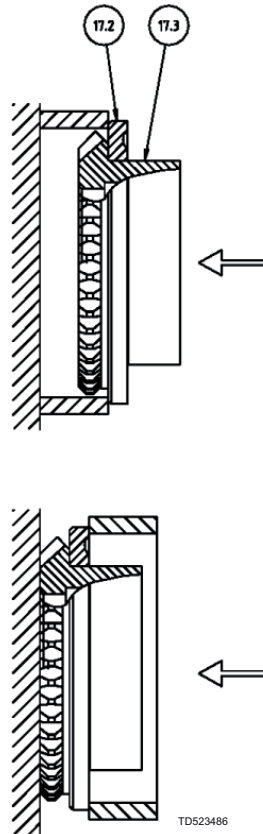

7 Trouble shooting guide

MultiJet 25

Symptom: Slow rotation or failure of the machine to rotate:

Possible Causes

Loose Cap nut
Wear

No or insufficient liquid flow

Fault finding

Check that the torque of the Cap nut (23) is at least 25 Nm. Remove Cap nut (23) and check Washer (22) for wear and signs of corrosion - replace if needed.

- a). Check if supply valve is fully open.
- b). Check if inlet pressure to machine is correct.
- c). Check supply line/filter for restrictions/clogging.
- d). Remove Nozzles and check for clogging. If blocked, carefully clean Nozzle without damaging Nozzles vanes and Nozzle tip.
- e). Remove Cone (see page 22) and check for clogging in Impeller of inlet guide inside Cone and in Impeller area.

If large particles repeatedly get jammed in the machine, install filter or reduce mesh size of installed filter in supply line.

Foreign material or material build-up

- a). Impeller jammed
- b). Turbine shaft sluggish in Bearing
- c). Planet gear jammed/sluggish

- d). Stem or Hub jammed/sluggish

Insert Screwdriver in Screw in top of Turbine shaft and easily turn Turbine shaft clockwise. If any resistance is recognised, disassemble machine to localise cause.

Remove Turbine shaft with Impeller and Carrier assembly (see page 22) and remove foreign material.

Remove Turbine shaft with Impeller (see page 22) and clean Bearing.

Remove foreign material from Planet wheels and internal gears. Check rotation of Planet wheels. If restriction is recognised, disassemble Carrier assembly (see page 22) and remove material build up, especially on Shafts and bushes in Planet wheels.

Remove Carrier assembly (see page 22). Turn Hub cover and check unrestricted rotation. Remove Stem and Hub (see page 22 ff). Remove foreign material/ material build-up on Stem, Hub and inside Nut w. ball race. Clean Ball races and Ball retainer with balls. Assemble Stem/Hub, Ball retainer with balls and Stem/Hub nut with ball race. Remove Stem and Hub (see page 22 ff). Clean teeth on Stem and Hub.

- e). Bevel gears jammed

Wear

- a) Slide bearings
- b) Bearings for Turbine shaft
- c) Planet wheels
- d) Shafts for Planet wheels

- e) Turbine shaft

See page 19.

See page 19.

See page 19.

Check clearance of Planet wheels on Shafts. Transverse movement should not exceed 0.3 mm.

Check clearance in Carrier bearing and Bearing for Turbine shaft. Transverse movement should not exceed 0.3 mm. Also inspect teeth for wear.

Mechanical defects

- a) Planet wheels. Teeth broken
- b) Planet wheel can not rotate on Shafts/ Shafts bent
- c) Damaged teeth on Bevel gear

Replace Planet wheel.

Replace Shafts for Planet wheels.

Inspect teeth on Stem and Hub for deformation. Mount Hub and Stem in Body (See page 24). Hold Body in upside down position and rotate Hub to check that bevel gears can work together. If damaged: Replace Stem and/or Hub.

If hard particles get stuck between Stem nut and Stem or Hub nut and Hub, the particles will damage the parts. The damaged parts should be replaced.

- d) Damage on Stem and Hub-nut

8.1 Technical data

Weight of machine:	5.1 kg (11.2 lb)
Working pressure:	3-8 bar (40-115 psi)
Recommended inlet pressure:	5-7 bar (70-100 psi)
Max. inlet pressure:	8 bar (115 psi)
Max. recommended working liquid temperature:	95°C (200°F)
Max. recommended working steam temperature:	140°C (284°F)
Max. ambient temperature:	140°C (284°F) when not operated
Materials:	Stainless steel AISI 316L, SAF 2205, PFA, PEEK, PVDF, A4/EPDM, Hastelloy C22, Hastelloy C276, PEEK, Viton, PFA
Surface finish:	External surface finish: Mat

Principal dimensions in mm

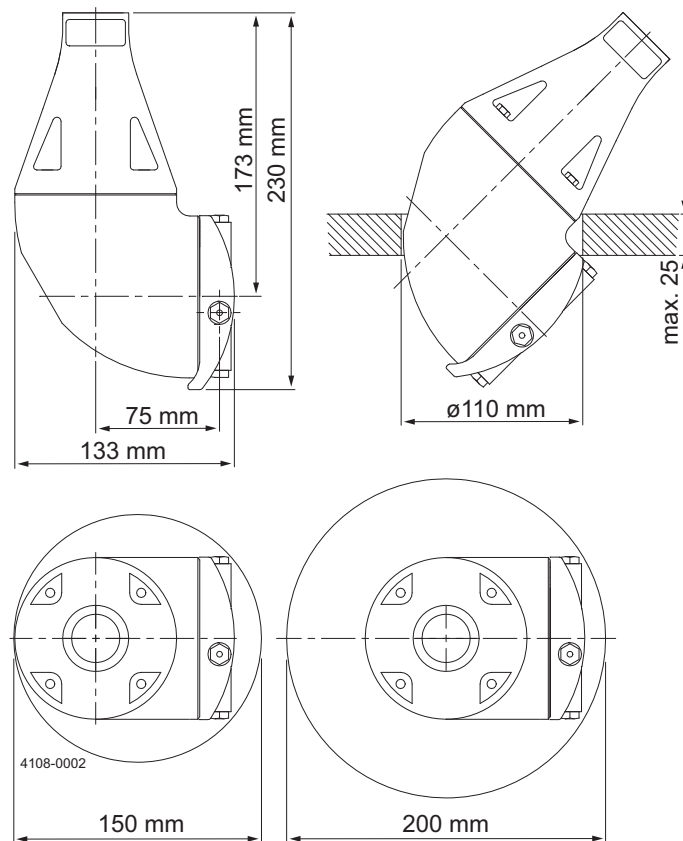

Minimum required passage: ø110 mm (4.33 inch) at flange thickness 25 mm (0.98 inch). Otherwise ø150 mm (5.90 inch).

8 Technical data

MultiJet 25

Performance Data:

Flow rate

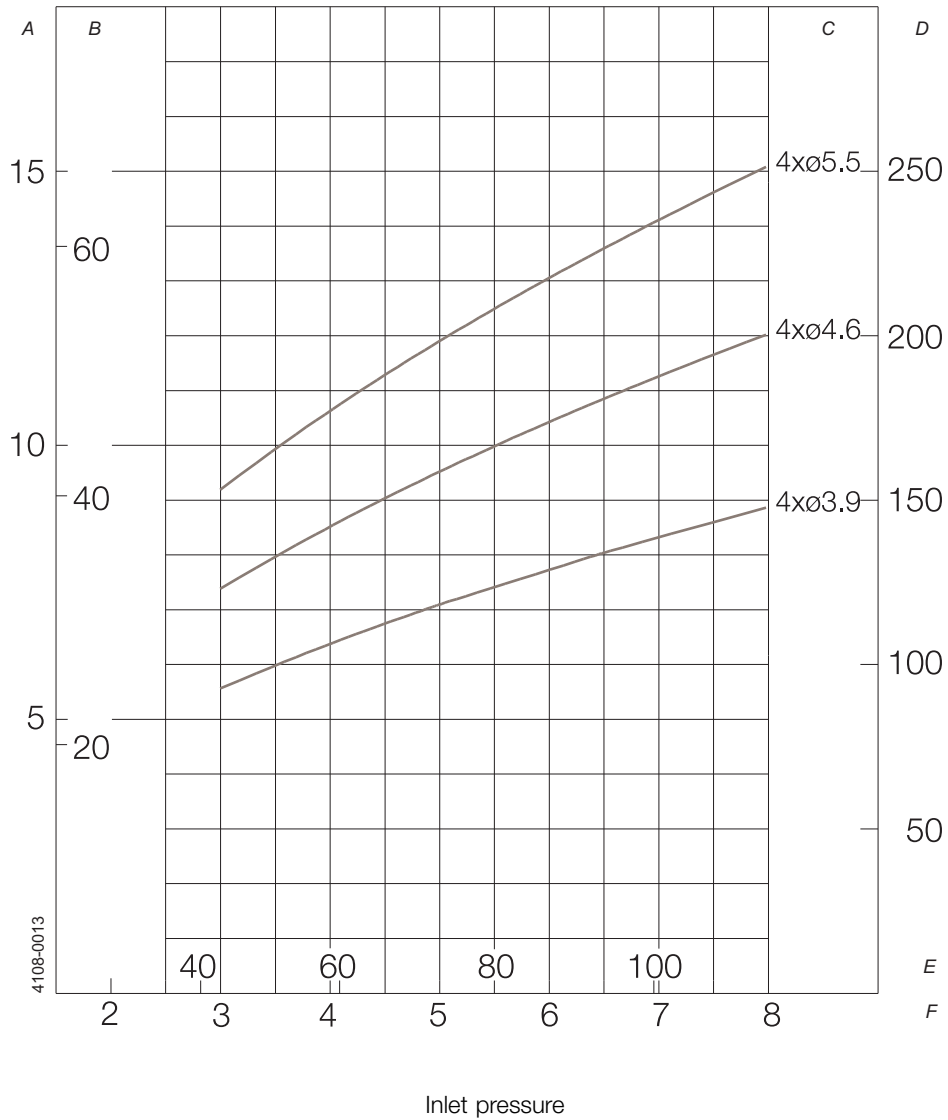

A: m³/h

B: USgpm

C: nozzle sizes

D: l/min.

E: psi

F: bar

Performance Data:

Throw length

 Max. static
 Effective
TD523321

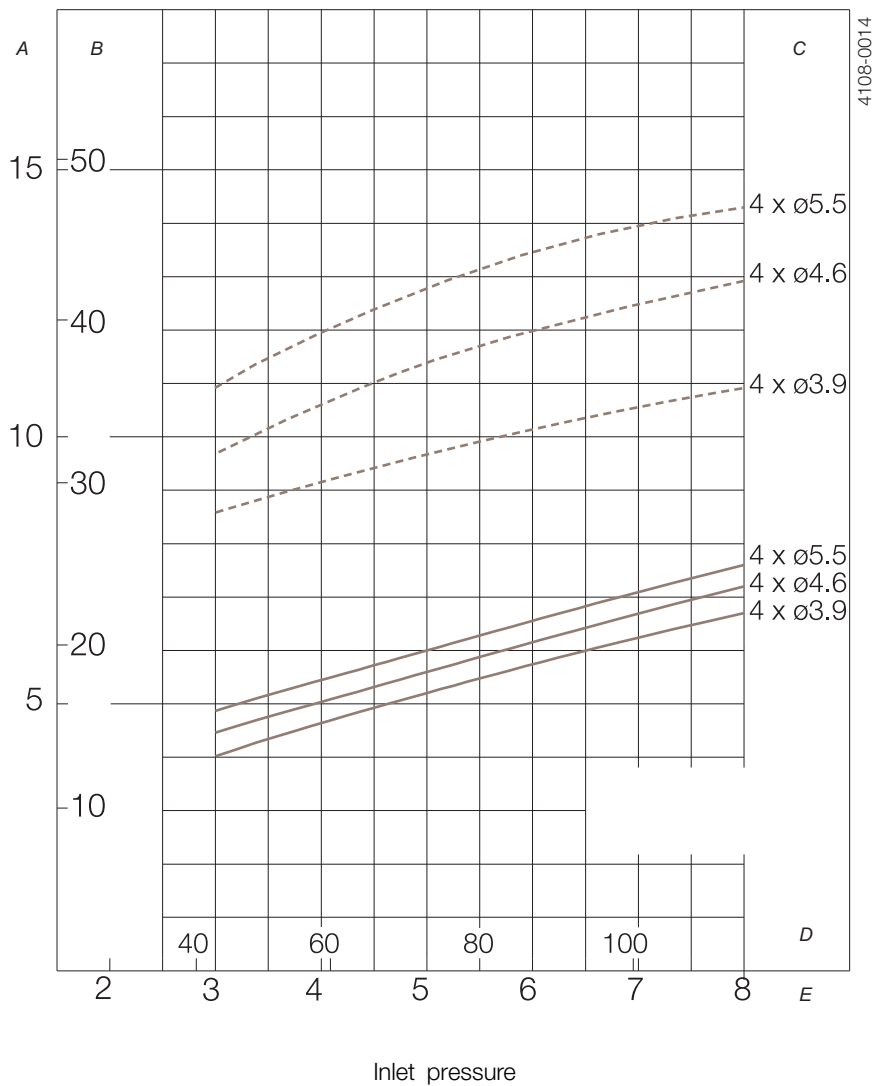

A: m

B: ft

C: nozzle sizes

D: psi

E: bar

Note: Throw lengths are measured as horizontal throw length at static condition. Vertical throw length upwards is approx. 1/3 less. Effective throw length is defined as impact centre of jet 250 mm water column (50 lbs/sq.ft). Effective throw length varies depending on jet transverse speed over surface, substance to be removed, cleaning procedure and agent. The inlet pressure has been taken immediately before the machine inlet. In order to achieve the performance indicated in the curves, the pressure drop in the supply lines between pump and machine must be taken into consideration.

8 Technical data

MultiJet 25

Performance Data:

Cleaning Time, f. complete Pattern (=8 cycles)

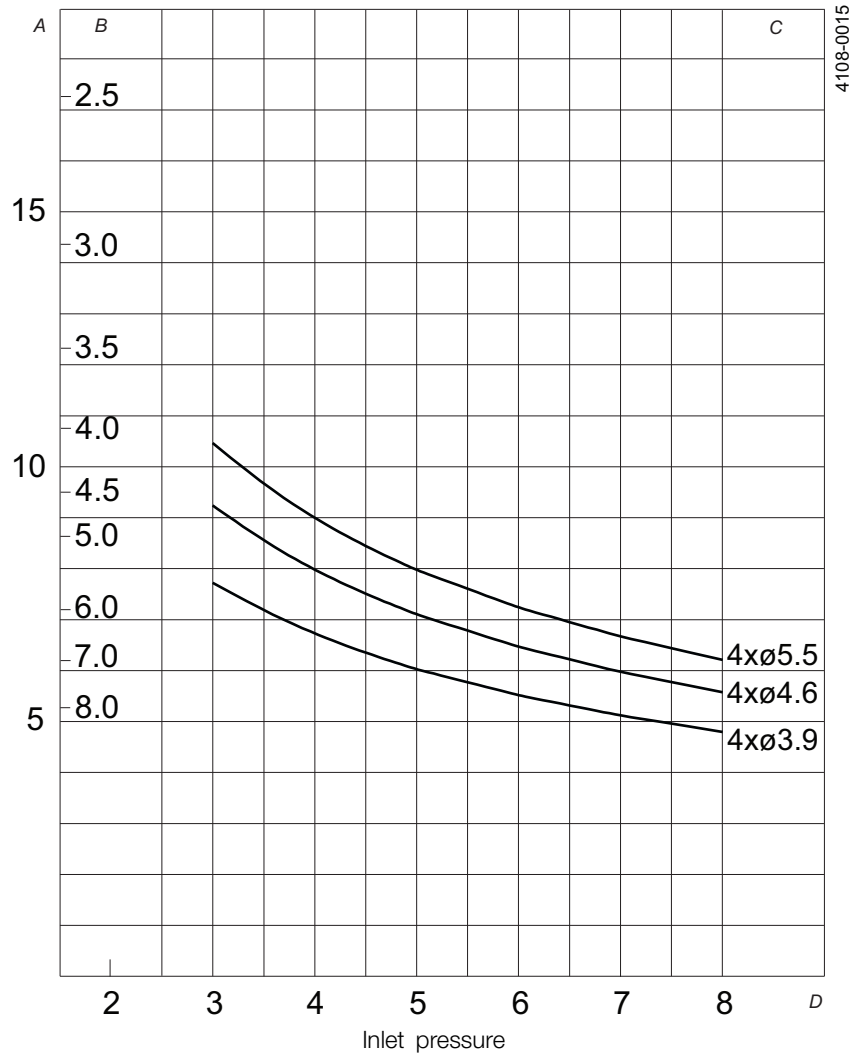

A: min.

B: RPM of machine body

C: nozzle sizes

D: bar

This manual covers the product program for Alfa Laval Toftejorg MultiJet 25 tank cleaning machine

9.1 Standard configurations

Alfa Laval Toftejorg MultiJet 25 options

Connection	Nozzles (mm) (1/2" thread conn.)	Standard Article No.
1" BSP, Female	4 x ø3.9	TE20G100-xx
	4 x ø4.6	TE20G102-xx
	4 x ø5.5	TE20G104-xx
1" NPT, Female	4 x ø3.9	TE20G120-xx
	4 x ø4.6	TE20G122-xx
	4 x ø5.5	TE20G124-xx

See page 33 for choices of sanitary welding connectors

Index no.:

TE20GXXX (no postfix): version w. PVDF impeller

TE20GXXX-X2: version w. PEEK impeller

9.2 Available add-ons

TE20XXXX-7X:	ATEX/IECEX
--------------	------------

Explanation to Add-ons

ATEX/IECEX		<p>ATEX/IECEX includes: ATEX/IECEX certified machine for use in explosive atmospheres. Category 1 for installation in zone 0/20 in accordance with directive 2014/34/EU.</p> <p>II 1G Ex h IIC 85°C...175°C Ga II 1D Ex h IIIC T85°C...T140°C Da</p>
------------	---	--

9 Product programme

This manual covers the product program for Alfa Laval Toftejorg MultiJet 25 tank cleaning machine

This manual covers the product program for Alfa Laval Toftejorg MultiJet 25 tank cleaning machine

9.3 Available welding connections

Welding adapter (see right) with sealing assembly between Down pipe, Welding adapter and machine.

Welding connections are ordered separately.

Pipe	Demensions in mm	Connection thread	Article no.
1" ISO thread pipe:	ø33.7 x 3.25	1" BSP	TE52D030
1" ANSI Sch.40S:	ø33.4 x 3.38	1" NPT	TE52D031
1 ½" ISO Dairy pipe:	ø38 x 1.2	1" BSP	TE52D032

Standard cone

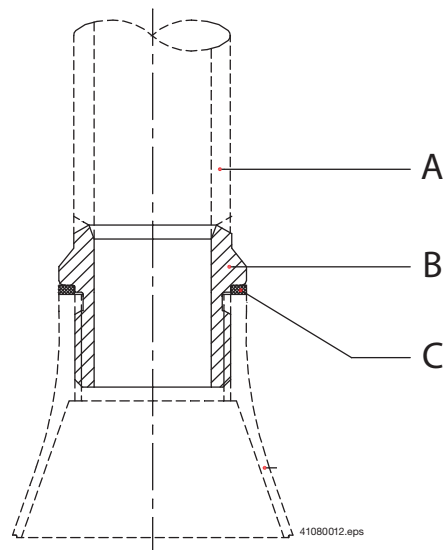

- A: Down pipe
- B: Welding adapter
- C: Seal PTFE

10 Parts list and drawing, service kits and tools

MultiJet 25

10.1 Alfa Laval Toftejorg MultiJet 25

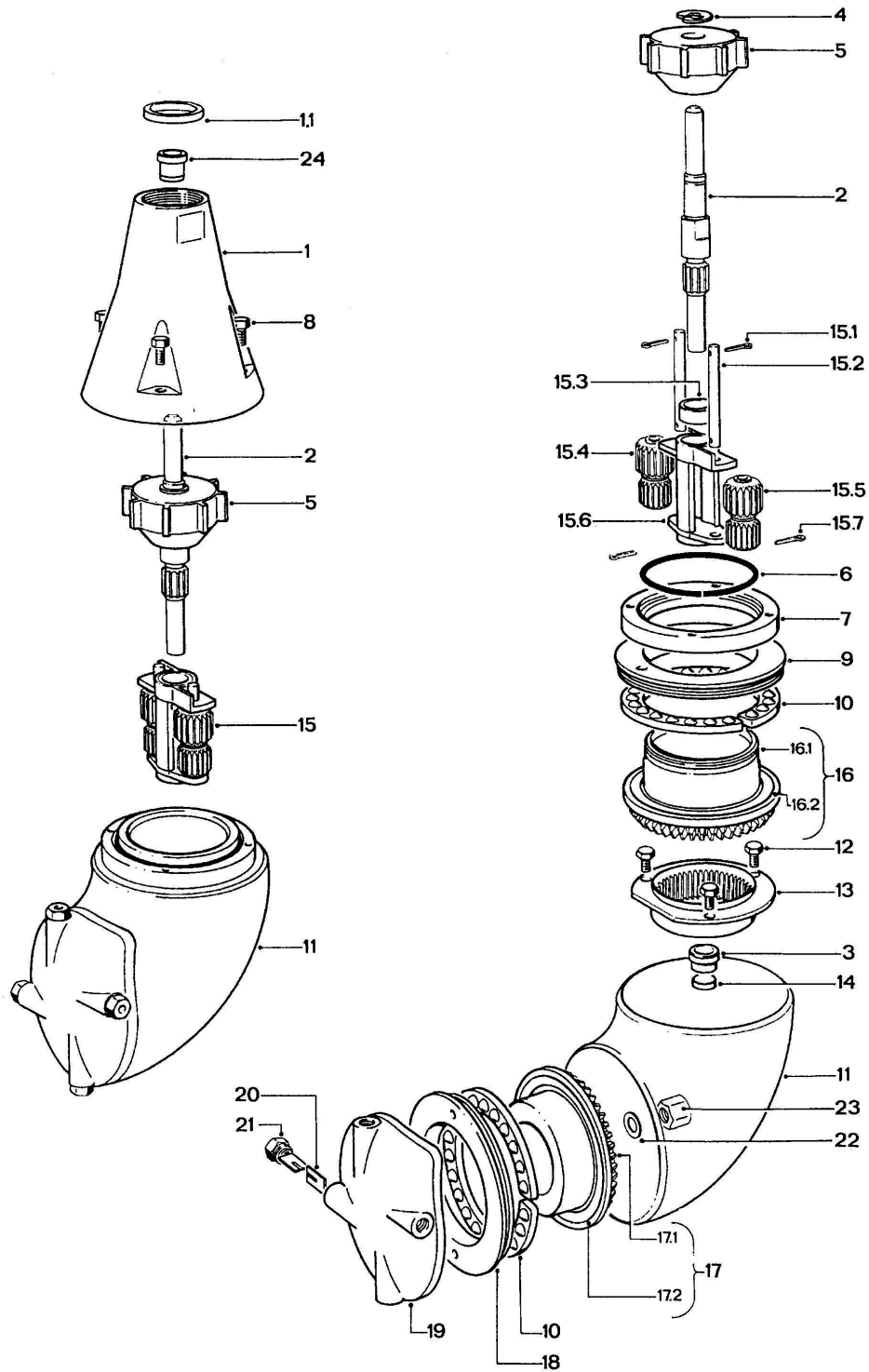

10 Parts list and drawing, service kits and tools

MultiJet 25

Parts list

Pos.	Qty	Denomination
1	□	1 Cone
2		1 Turbine shaft
3	◆●	1 Bearing for Turbine shaft
4		1 Circlip
5	□	1 Impeller
6		1 Retainer spring
7		1 Retaining ring
8		4 Screw
9	●	1 Stem nut with ball race
10	●	2 Ball retainer with balls
11		1 Body
12		3 Screw
13		1 Internal gear
14	◆●	1 Slide bearing
15		1 Carrier assembly
15.1	●	2 Cotter pin
15.2		2 Shaft for Planet wheel
15.3	◆●	1 Bearing for planet gear carrier
15.4	◆●	1 Planet wheel I
15.5	◆●	1 Planet wheel II
15.6		1 Planet gear carrier
15.7		2 Cotter pin (= pos. 15.1)
16		1 Stem complete
16.1		1 Stem
16.2		1 Ball race
17		1 Hub complete
17.1		1 Hub
17.2	●	1 Ball race (= pos. 16.2)
18	●	1 Hub nut with ball race
19	□	1 Hub cover
20		8 Nozzle vane
21	□	4 Nozzle
22	◆●	1 Washer
23		1 Cap nut
24	◆●	1 Bearing for turbine shaft top

Configuration according to delivery note/order.

Parts marked with ◆ are included in the Minor Service Kit for MultiJet 25: TE20G299

Parts marked with ● are included in the Major Service Kit for MultiJet 25: TE20G288

The machine can be delivered with ATEX/IECEX certification.

See page 31 for more information on available add-ons.

Please note that some of the polymer parts are in PEEK, which is not resistant to concentrated sulfuric acid.

Please refer to the Spare Part Manual for information on item numbers and materials. The Spare Part manual is available from the on-line Alfa Laval product catalogue Anytime or the Close at hand spare part catalogue.

10 Parts list and drawing, service kits and tools

MultiJet 25

10.2 Tools

Alfa Laval Tofteborg MultiJet 25 Tool kit
Item number TE81B085

Denomination	Tool item number
Caliper	TE369
Socket wrench w. pin	TE462A
Spanner for MultiJet 25 (flat jawed)	TE81B040
Spanner (13 mm)	TE81B041

Torque wrench tool
Item number TE81B087

Denomination	Tool item number
Torque wrench with interchangeable ratchet head	TE81B088
Ring insert tool for torque wrench	TE81B089

11.1 Service and Repair

Upon every return of a product, no matter if for modifications or repair, it is necessary to contact your local Alfa Laval office to guarantee a quick execution of your request.

You will receive instructions regarding the return procedure from your local Alfa Laval office. Be sure to follow the instructions closely.

11.2 How to Order Spare Parts

On the parts drawings as well as on all instruction drawings, the individual parts have a position number, which is the same on all drawings. From the position numbers, the part is easily identified in the parts list, page 34.

Individual parts should always be ordered from the parts list, page 34. Item number and denomination should be clearly stated. Please refer to the Spare part manual for information on item numbers. The Spare part manual is available from the on-line Alfa Laval product catalogue Anytime or the Close at hand spare part catalogue.

Please also quote the type of machine and serial number. This will help us to help you. The type and serial numbers are stamped on the body of the tank cleaning machine.

11.3 How to contact Alfa Laval Kolding A/S

For further information please feel free to contact:

Alfa Laval Kolding A/S

31, Albuen - DK 6000 Kolding - Denmark

Registration number: 30938011

Tel switchboard: +45 79 32 22 00 - Fax switchboard: +45 79 32 25 80

www.toftejorg.com, www.alfalaval.dk - info.dk@alfalaval.com

Contact details for all countries are continually updated on our websites

How to contact Alfa Laval

Contact details for all countries are continually updated on our website.

Please visit www.alfalaval.com to access the information directly.

© Alfa Laval Corporate AB

This document and its contents is owned by Alfa Laval Corporate AB and protected by laws governing intellectual property and thereto related rights. It is the responsibility of the user of this document to comply with all applicable intellectual property laws. Without limiting any rights related to this document, no part of this document may be copied, reproduced or transmitted in any form or by any means (electronic, mechanical, photocopying, recording, or otherwise), or for any purpose, without the expressed permission of Alfa Laval Corporate AB. Alfa Laval Corporate AB will enforce its rights related to this document to the fullest extent of the law, including the seeking of criminal prosecution.