



Instruction Manual

Alfa Laval GJ PF-FT



Covering:
Standard Machines
First published: 2015-07

ESE032025-EN1 2015-07

Original manual

The information herein is correct at the time of issue but may be subject to change without prior notice.

1. Safety	4
1.1. Important Information	4
1.2. Warning Signs	4
1.3. Safety Precautions	5
2. Introduction	6
2.1. Description	6
2.2. Intended Use	6
2.3. Patents and Trademarks	6
2.4. Marking	6
3. Installation	7
3.1. Unpacking/Delivery	7
3.2. Installation	8
3.3. Recycling Information	10
4. Operation	11
4.1. Operation/Control	11
4.2. Trouble Shooting	12
4.3. Cleaning Solution Leakage	13
4.4. Poor Cleaning Performance	14
4.5. Recommended Cleaning	15
5. Maintenance	16
5.1. General Maintenance	16
5.2. Preventative Maintenance	17
5.3. General Dismantling	18
5.4. Inspection and Service of Components	19
5.5. Reassembly	21
6. Technical Data	23
6.1. Technical Data	23
6.2. Performance Data	24
6.3. Dimensions	26
6.4. Trax Simulation Tool	27
7. Parts List and Service Kits	28
7.1. AL GJ 10 View	28
7.2. Assembly Drawings – 1, 2 & 3	29
7.3. Assembly Drawing – 4	30
7.4. Assembly Drawings – 5 & 6	31
7.5. Assembly Drawing – 7, 8, 9, 10 & 11	32
7.6. Assembly Drawing – 12	34
7.7. Assembly Drawings – 13, 14, 15, 16 & 17	35
7.8. Assembly Drawing – 18	37
7.9. Parts List	38
7.10. Minor Service Kit	40
7.11. Major Service Kit	41

1 Safety

*Unsafe practices and other important information are emphasized in this manual.
Warnings are emphasized by means of special signs.
Always read the manual before using the tank cleaning machine!*

1.1 Important Information

WARNING

Indicates that special procedures must be followed to avoid serious personal injury.

CAUTION

Indicates that special procedures must be followed to avoid damage to the tank cleaning machine.

NOTE

Indicates important information to simplify or clarify procedures.

1.2 Warning Signs

General warning:



Dangerous electrical voltage:



Caustic agents:



All warnings in the manual are summarized on this page.

Pay special attention to the instructions below so that severe personal injury and/or damage to the tank cleaning machine are avoided.

1.3 Safety Precautions

Installation:

Always read the technical data thoroughly. (See chapter 6 Technical Data)

Any tank-cleaning machine can develop a static electricity charge while in operation.

If the tank being cleaned contains a combustible liquid or vapor having a risk of ignition or explosion, it is imperative to have the Alfa Laval Gamajet properly grounded using the provided location on the unit.



Operation:

Always read the technical data thoroughly. (See chapter 6 Technical Data)

Necessary precautions must be taken if leakage occurs as this can lead to hazardous situations.



Always handle lye and acid with great care.

When an Alfa Laval Gamajet is operating, there should be covers over every tank opening.



These covers should be sealed well enough to withstand the full force of the jet striking the cover plate.

If the cleaning solution were hot, corrosive, or toxic, a leak would present a serious hazard to any personnel

in the immediate vicinity or to any exposed electrical equipment.



Warning: Any tank-cleaning machine can develop a static electricity charge while in operation. If the tank being cleaned contains a combustible liquid or vapor having a risk of ignition or explosion, it is imperative to have the Alfa Laval Gamajet properly grounded using the provided location on the unit.



Maintenance:

Always read the technical data thoroughly. (See chapter 6 Technical Data).

Never service the tank cleaning machine when it is hot.

Always use Alfa Laval genuine spare parts.



Transportation of the tank cleaning machine:

Always drain the tank cleaning machine head and accessories of any liquid

Always use original packaging or similar during transportation

2 Introduction

2.1 Description

The Alfa Laval GJ PF-FT is a fluid-driven (turbine-driven) 360° rotary nozzle machine designed for cleaning the interior surfaces of a wide variety of process vessels with a minimum opening of 174.7mm (6.875 inches) in diameter for a pin drive machine or 98.5mm (3.875 inches) for a clutch machine and the nozzles in the vertical position and 97.3mm (3.830 inches) for the low profile machine regardless of nozzle position. It is powered entirely by the cleaning solution and it requires no electricity, compressed air or lubricant for operation. The Alfa Laval GJ PF-FT is designed for both portable and CIP (Clean In Place) applications. If the Alfa Laval GJ PF-FT is permanently mounted inside a tank, we strongly recommend inspecting the unit every few hundred hours of operation.

Warning: In some conditions, the Alfa Laval GJ PF-FT may be allowed to be immersed while left in the tank. It is strongly recommended that you have prior approval from Alfa Laval Gamajet Equipment to ensure this will not harm the machine in any way. Failure to comply with this restriction may void the warranty!!!

In order to handle the broadest possible range of applications, the stainless steel Alfa Laval GJ PF-FT is available with an extensive selection of nozzle sizes, stators (non-rotating turbine), and O-ring materials. The nozzles are available in several interchangeable sizes that range from 6.4mm to 9.5mm (1/4" to 3/8"). The Alfa Laval GJ PF-FT wash cycle time can be adjusted for special applications by changing the stator and/or nozzle size. Interchangeable stators and nozzle sizes are available for either low or high pressures and/or flow rates. The performance capabilities of these options are detailed in Section 7 – Technical Data.

2.2 Intended Use

It is to be verified by the end-user:

- That the tank cleaning machine is in conformity with respect to tank, vessel or container size in which it will be used.
- That the construction materials (both metallic and non-metallic) are compatible with product, flushing media, cleaning media, temperatures and pressure under the intended use.

2.3 Patents and Trademarks

This Instruction Manual is published by Alfa Laval Tank Equipment without any warranty. Improvements and changes to this Instruction Manual may at any time be made by Alfa Laval Tank Equipment without prior notice. Such changes will, however, be incorporated in new editions of this Instruction Manual.

© Alfa Laval Tank Equipment, All rights reserved.

The Alfa Laval logotype is a trademark or the registered trademark of Alfa Laval Corporate AB. "Gamajet" is a trademark or registered trademark of Alfa Laval Tank Equipment. The Alfa Laval GJ PF-FT product has patent in the US (US 6,123,271). Other products or company names mentioned herein may be the trademarks of their respective owners. Any rights not expressly granted herein are reserved.

2.4 Marking

Alfa Laval Gamajet tank cleaning machines are all marked to allow recognition of machine type, machine name, Serial number and manufacturing address. The marking is placed on the body of the tank cleaning machine.

Alfa Laval Tank Equipment - Exton, PA
Patent #: 6,123,271



3.1 Unpacking/Delivery

Step 1

CAUTION
Alfa Laval cannot be held responsible for incorrect unpacking.

Check the delivery for:

1. Complete Cleaning Machine
 2. Delivery note
-

Step 2

Remove any packing materials

Step 3

Inspect the tank cleaning machine for visible transport damage

Inspection!

3 Installation

Read the instructions carefully and pay special attention to the warnings! Always check the tank cleaning machine before operation.

3.2 Installation

Step 1



Always read the technical data thoroughly.
(See chapter 6 Technical Data)

Step 2

Assembly

Every Alfa Laval Gamajet is operationally tested before shipment and is ready to run after unpacking. No assembly is required prior to use. The Alfa Laval GJ PF-FT has been configured to meet the operating conditions (at the Alfa Laval GJ PF-FT, not at the pump) given to us, e.g. pressure, flow, temperature, cycle time, chemical adders, etc.

Note: Any change to the original operating conditions will affect the Alfa Laval GJ PF-FT accordingly.

Warning: Do not force Tee Housing (Pos. 8) to rotate. Doing so may cause damage to the internal components.

Step 3

Inlet Connections

The standard inlet connections for the Alfa Laval GJ PF-FT are a 1-1/2" slip-fit or a 1-1/2" Tri-Clover. Others inlets are available. It is recommended that when using the pipe thread the mating male thread should be wrapped with PTFE pipe joint tape prior to mounting. This will minimize any chance of leakage and will make subsequent removal much easier.

Step 4

Mounting

Before mounting the Alfa Laval GJ PF-FT, make sure the supply line has been adequately flushed. It can be mounted on a rigid 1-1/2" pipe using appropriate mounting methods. In most applications, the machine will be mounted with the inlet connection pointing up; however, the Alfa Laval GJ PF-FT will function at any orientation.

The Alfa Laval GJ PF-FT can be suspended from the top of the tank via a flexible hose. The dual nozzle machine is designed to have balanced forces in order to keep it centered even while hanging. We do not, however, recommend attaching the machine to a flexible hose while in the inverted or horizontal orientation. This form of mounting is not rigid and, thus, will not maintain the machine's position in the tank.

Warning: When attaching the Alfa Laval GJ PF-FT onto the supply pipe, ALWAYS apply the wrench to the Sanitary Inlet (11) at the top/inlet of the unit. Never use a wrench on the Stem (7), Tee Housing (8), or Tee Housing Cap (14) to tighten the unit onto the pipe. Doing so risks internally damaging the machine.

Step 5

Location inside Tank

Generally, a single Alfa Laval GJ PF-FT will be positioned in the approximate center of the vessel in order to equalize the cleaning radius in all directions. Some vessels, however, may have specific cleaning problems such as coils or heavy deposits such as the liquid level line (bathtub ring). In these situations, the Alfa Laval GJ PF-FT should be located closer to the difficult area for the best cleaning results.

Tanks with internal mechanisms or structures such as an agitator shaft, impellers or baffles will require careful positioning to minimize the "shadow" on areas which do not receive direct jet impact. Sometimes, more than one machine, or, more than one placement of a single machine, may be necessary to avoid shadow problems or "striping."

Read the instructions carefully and pay special attention to the warnings! Always check the tank cleaning machine before operation.

Step 6

Entry Openings

When using the Alfa Laval GJ PF-FT, the vessels being cleaned must provide entry openings large enough to avoid interference during insertion and removal. The minimum opening size required for the Alfa Laval GJ PF-FT is 98.5mm (3.875") in diameter for free-hand installation of a clutch driven machine and the nozzles in the vertical position. For a pin drive machine, the minimum opening size required is 174.7mm (6.875"). A 97.3mm (3.830") opening is needed for the low-profile version of the Alfa Laval GJ PF-FT regardless of the nozzle position.

Step 7

Vessel Drainage

If it is necessary to clean the floor of a vessel, remember that standing liquid will diminish the effectiveness of the Alfa Laval GJ PF-FT by covering any soils underneath. Wherever possible, the tank floor should be pitched toward the drain and the drainage opening should be large enough to eliminate or reduce any liquid buildup or puddling. If gravity alone is insufficient, a scavenger or stripper pump should be connected to the drain to suck out the excess wash fluid. In extreme cases, it may be necessary to use smaller nozzles on the Alfa Laval GJ PF-FT, or even to operate it intermittently to allow time for draining.

Step 8

Filters and Strainers

All tank cleaning systems should be equipped with a filter or strainer that will trap solids **1/16" and larger (150 micron, 100 mesh)**, as these will not pass through the Alfa Laval GJ PF-FT. These particles can become caught in one of the internal passages of the machine and cause it to stop turning or reduce its cleaning effectiveness due to a loss of flow. It will then be necessary to disassemble the machine and remove the blockage.

In recirculated (closed-loop) cleaning or any other application where the cleaning solution may carry abrasive solids in suspension, adequate filtration is a must. These particles can be extremely destructive to the Alfa Laval GJ PF-FT, pumps, valves, and other system components. Filters, properly installed and maintained, will more than pay for themselves with lower overall operating costs in these applications. Furthermore, to ensure that clogged filters or strainers are cleaned, we recommend using automatic self-cleaning models.

Step 9

Capacity of Supply Pump

The Alfa Laval GJ PF-FT can be used with either a centrifugal or positive displacement (constant volume), PD, style pump. In most cases, if the Alfa Laval GJ PF-FT is to be used with a centrifugal pump, the Alfa Laval GJ PF-FT should be configured so that the pump will operate close to its best efficiency point. The end user must, therefore, take all of the plumbing, elevation, and Alfa Laval GJ PF-FT pressure/flow rate requirements into account.

If a PD style pump (i.e. piston pump, plunger pump, or mechanical diaphragm pump, etc.) will be supplying the wash fluid to the Alfa Laval GJ PF-FT, a different set of rules apply. PD pumps are fixed volume pumps whose flow rate is dependent upon the rotational speed of the pump; the pumps also have a pressure rating which is the **maximum** operating pressure. **Note: Do not confuse the maximum operating pressure of a PD pump with the actual operating pressure, the actual operating pressure is dictated by the fixed flow rate of the pump and the Alfa Laval GJ PF-FT / plumbing system.** If a PD pump is used, the Alfa Laval GJ PF-FT should be sized to, first, match the flow capability of the pump and, second, not exceed the Alfa Laval GJ PF-FT's or pump's maximum operating pressure (taking the pressure rating of the plumbing system into account, also).

Warning: For high-pressure applications (over 10bar / 145psig), the pressure of the system must "ramp up" to its operating pressure. If the system experiences a pressure spike or pressure increases at a rate of more than 10bar / 150psi per second, the machine may be damaged and parts will wear out prematurely. Damage resulting from this water hammer affect is not covered by the warranty.

3 Installation

Read the instructions carefully and pay special attention to the warnings! Always check the tank cleaning machine before operation.

3.3 Recycling Information

- **Unpacking**

- Packing material consists of wood, plastics, cardboard boxes and in some cases metal straps.
- Wood and cardboard boxes can be reused, recycled or used for energy recovery.
- Plastics should be recycled or burnt at a licensed waste incineration plant.
- Metal straps should be sent for material recycling.

- **Maintenance**

- All metal parts should be sent for material recycling.

- **Scrapping**

- At end of use, the equipment must be recycled according to relevant, local regulations. Beside the equipment itself, any hazardous residues from the process liquid must be considered and dealt with in a proper manner. When in doubt, or in the absence of local regulations, please contact your local Alfa Laval sales company.
-

Read the instruction carefully and pay special attention to the warnings!

4.1 Operation/Control

Step 1



Always read the technical data thoroughly. See chapter 6 Technical Data

CAUTION

Alfa Laval cannot be held responsible for incorrect operation/control.

Step 2



Never touch the tank cleaning machine or the pipelines when pumping hot liquids.

Step 3

Initial Startup

Every Alfa Laval GJ PF-FT that ships is accompanied by a Birth Certificate. This document indicates how the machine performed in our testing tank before it shipped based on the operating conditions supplied to Alfa Laval Gamajet. To ensure the longest possible life of the machine, please verify the operating conditions and, most importantly, the machine's cycle time. The cycle time can be measured by, first, picking a fixed point inside of a vessel as a reference and, second, timing how long it takes the same nozzle to pass back over that point in the vessel. (This, naturally, will not be the exact same spot because the spray pattern is indexing.) The measured time in seconds directly corresponds to the machines full cycle time in minutes. In other words, a single 10-second rotation translates to a 10 minute full cycle time.

4 Operation

*Pay attention to possible faults
Read the instructions carefully*

4.2 Trouble Shooting

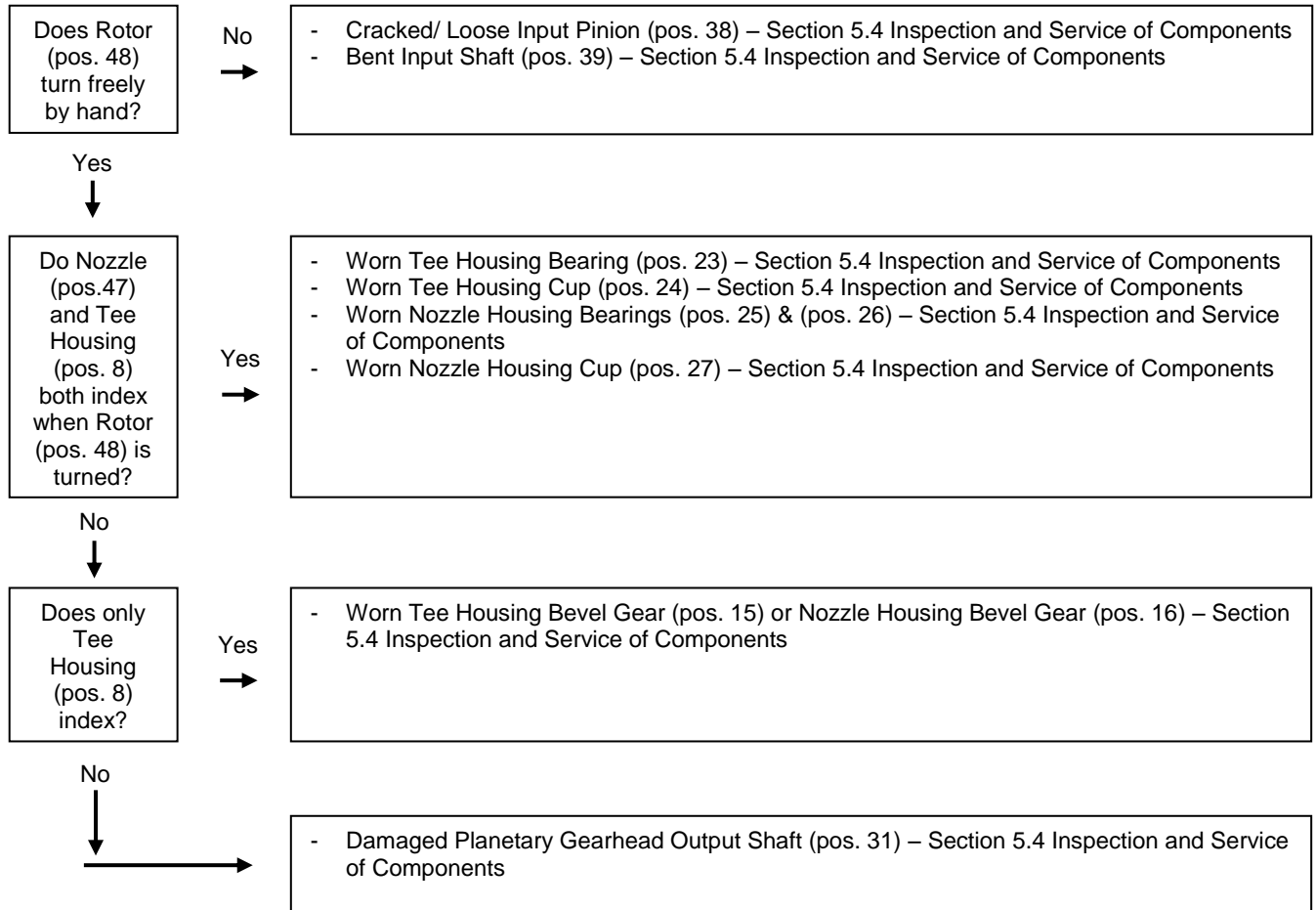

*Pay attention to possible faults
Read the instructions carefully*

Step 1

Insufficient Flow

The Alfa Laval GJ PF-FT was configured to meet certain operating conditions outlined at the time of the initial sale, such as flow rate (m³/hr)(GPM), pressure (bar)(PSI), temperature, chemical content of the wash fluid, cycle time, etc. If the Nozzle (47) size is too small and/or the opening at the bottom of the Stator (12) is too large, the Tee Housing (8) will not turn. Look for restrictions in the fluid supply such as a clogged filter, kinked hose, or deposits in the piping.

Step 2

Tight Clearances

A recently overhauled Alfa Laval GJ PF-FT may fail to operate when first returned to service. If the machine seems otherwise fine, try running it with at least one Nozzle (47) removed. The reduction in pressure and additional flow will invariably be enough to overcome the extra resistance of new Bearings and Seals. Twenty minutes of operation should loosen the machine to run normally with the Nozzles reinstalled.

Step 3

Debris Inside

Loosen the Collar Set Screw (34), remove the Sanitary Inlet (11), and then lift out the Stator (12). Look for and remove any debris caught in the Stator (12) and the vanes of the Rotor (48). Remove any material wound around the Input Shaft (39). In addition, check for any debris caught in the outlet holes of the Stem (7), the nose of the Tee Housing (8), the Nozzle Housing (9), and the Nozzles (47).

4.3 Cleaning Solution Leakage

Note: The Alfa Laval GJ PF-FT is a self-flushing machine and thus has up to 15% leakage designed into the machine. Excessive leakage may indicate a larger issue.

- Worn Bearings and Seals

Leakage from the Tee Housing (8) or Nozzle Housing (9) usually indicates worn Housing Bearings and Seals. Inspect them for wear (sealing lips are worn to a smooth surface) or damaged lips or loss of spring tension (indicated by excessive dry deposits of dirty or abrasive cleaning solution on the spring), and replace as required.

- Worn Housing Cups

Inspect the Housing Cups (24) and (27) for excessive wear (grooved or scored). Replace any that show distinct grooves.

- Worn Collar O-rings

Severe leakage between the Sanitary Inlet (11) and Cap (6) may indicate worn or damaged Collar O-rings (3) and (54). Remove the (11) as described in Section 6.3 – General Dismantling, and inspect the (3) and (54) for signs of damage or wear.

- Worn Clutch O-ring

Severe leakage above the Tee Housing (8) may be the result of excess wear on the Clutch O-ring (33). There will be leakage through this point regardless due to the normal clutch operation, but severe leakage is not ordinary. Remove the Tee Housing (8) as described in the general disassembly instructions and inspect the (33) for damage or wear.

4 Operation

*Pay attention to possible faults
Read the instructions carefully*

4.4 Poor Cleaning Performance

- **Inadequate Flow and Pressure**

Check the pressure at the Alfa Laval GJ PF-FT inlet under actual operating conditions. The supply piping and hoses must be large enough to handle the flow rate required for the nozzle size being used to ensure adequate pressure.

Insufficient pressure may also result from line losses when the machine is far from the pump. If this is the case, the line size must be increased accordingly for long runs. Although the Alfa Laval GJ PF-FT will rotate at low flow rates, effective cleaning may require considerably more flow. Proper mechanical operation (the unit turns) is NOT the same thing as effective cleaning (the soils have been removed)! Contact Alfa Laval Tank Equipment if assistance is required.

- **Chemical Concentration and Temperature**

Verify that the cleaning solution is the correct compound and in the concentration needed for the deposit being cleaned. If heating is necessary, also check that the solution is at the proper temperature.

- **Plugged Nozzles**

Unscrew the Nozzles (47) and inspect for any debris.

- **Slow or no Rotation of the Housings**

This will result in partial or erratic washing coverage. Refer to previous sections for more information.

- **Alfa Laval GJ PF-FT Configuration**

Determine if the deposit being cleaned requires greater jet impact or longer jet dwell time (slower rotation) for more thorough scrubbing. Confirm that the Alfa Laval Gamajet nozzle size, turbine, and gearing are correct for the specific application. Refer to the machine's Birth Certificate for specific information regarding its configuration. Contact an Alfa Laval Tank Equipment representative if assistance is required.

- **Inadequate Drainage**

Ensure that the vessel drains the effluent (used wash fluid) as fast as it's being sprayed in through the Alfa Laval Gamajet. The floor of the vessel should be sloped or pitched toward the drain and the drainage opening should be large enough to gravity-drain the effluent from the vessel. If you still have puddling (build-up of the wash fluid so it covers the floor and shields the residues underneath), use some form of pump to remove the effluent.

The Tank Cleaning machine is designed for cleaning in place (CIP). CIP = Cleaning In Place. Study the instructions carefully and pay special attention to the warnings! NaOH= Caustic Soda. HNO3= Nitric acid.

4.5 Recommended Cleaning

Step 1



Always handle lye and acid with great care.

Caustic danger!



Always use rubber gloves!



Always use protective goggles!

Step 2



Never touch the pump or the pipelines when sterilizing.

Danger of burns!

Step 3



Always rinse well with clean water after using a cleaning agent.

Always rinse!

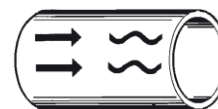

Clean Water

Cleaning agent

NOTE

Cleaning agents must be stored/disposed of in accordance with current regulations/directives.

5 Maintenance

*Maintain the Tank Cleaning Machine with care. Read the instructions carefully and pay special attention to the warnings!
Always keep Minor spare parts kit in stock.*

5.1 General Maintenance

Step 1



Always read the technical data thoroughly. (see chapter 6 Technical Data)

Step 2

Recommended spare parts:

Order service kits from the service kits list

(See 7.10 Minor Service Kit & 7.11 Major Service Kit)

Ordering spare parts:

Contact your local Alfa Laval Sales company.

*Maintain the Tank Cleaning Machine with care. Read the instructions carefully and pay special attention to the warnings!
Always keep Minor spare parts kit in stock.*

5.2 Preventative Maintenance

Step 1

Note

A rigorously implemented preventative maintenance program will significantly reduce repair costs over the life of the Alfa Laval Gamajet. The foundation of such a program is regularly scheduled inspections to discover and replace worn or damaged parts before they can cause the failure of other, more costly, components. The inspection intervals required will depend on the severity of the application, but a complete internal inspection at 100 hours of operation is recommended initially.

Step 2

Storage

The Alfa Laval Gamajet should be washed out with clean water after each use to remove any foreign material or soft substances left in the machine that may harden during storage and cause the Alfa Laval Gamajet to seize or lock up. A clean water rinse through the Alfa Laval Gamajet will also wash out any residues of chemical cleaners or recirculated wash water that could adversely affect the O-rings during prolonged contact in storage. The best position to store the machine is to stand it up with the inlet connection facing down.

Step 3

External Inspection Intervals

Before every shift, the Stator (12) and the Nozzles (47) should be inspected for debris. Examine the (12) by loosening the Set Screw (34), while holding on the flats of the Cap (6), remove the main section of the machine from the Sanitary Inlet (11). Look into each (47) for signs of debris or build-up.

Step 4

Internal Inspection Intervals

An interval of 100 hours is recommended initially. If all of the components are found to be in acceptable condition after the first 100 hours, the Alfa Laval Gamajet may then be inspected and routine preventive maintenance should be performed every 600 to 800 hours of operation, depending on the severity of use.

Step 5

Tips

All the Bearings, Bushings, Seals and O-rings are wear parts. Ideally, they should all be replaced, as a group, every 600 to 800 hours of operation, depending on the severity of use. If just one Bearing or Seal is worn or damaged, replace both it and its mate, not just the worn or damaged part. Verify that the Housing Cups (24) and (27) are not scored. Replacing new Bearings and Seals in scored Cups may prematurely wear the new Bearings and may cause premature failure of the Bearings and Seals.

5 Maintenance

Read the instructions carefully. The items refer to the parts list and service kits section.

5.3 General Dismantling

Step 1

Sanitary Inlet

Loosen the Set Screw (34) with a 3/32" Hex Key, minimum 2 turns.
Remove the Sanitary Inlet (11) and Stator (12).

Warning: Hold or turn on Stem (7). DO NOT hold or turn on Tee Housing (8) or Tee Housing Cap (14). Doing so will damage the Geartrain (drawing 6).

Step 2

Nozzle Housing

Unscrew the Nose Plate (10) with a 1/2" slotted screwdriver.
Pull the Nozzle Housing (drawing 15) from the nose of the Tee Housing (8) with the Nozzle Housing Upper Bearing (26).
Remove the inner Nozzle Housing Lower Bearing (25).

Step 3

Cap and Geartrain

Using pliers or a bench vise on the flats of the Cap (6), unthread it from the body (drawing 11).

Warning: Hold or turn on Stem (7). DO NOT hold or turn on Tee Housing (8) or Tee Housing Cap (14). Doing so will damage the Geartrain (drawing 6).

Pull the Geartrain (drawing 6) from the remainder of the body (drawing 11). Two slotted screwdrivers can be placed on either side of the Rotor (48) and used to lift the Geartrain out. This is only for leverage and should not be used if the Geartrain is jammed or stuck inside of the body.

Step 4

Body Assembly

Unthread the Tee Housing Cap (14) from the Tee Housing (drawing 8). **Note:** This is a **Left Hand** thread.
Remove the Stem Screws (32) with a 5/32" Hex Key, and Stem Base (drawing 9) from the Tee Housing (drawing 8).
Remove the Tee Housing (drawing 8) by pulling it from the Stem (drawing 7). The upper Tee Housing Bearing (23) will pull off with the Tee Housing.
Remove the lower Tee Housing Bearing (23) and Tee Housing Bevel Gear (drawing 10).

Read the instructions carefully. The items refer to the parts list and service kits section.

5.4 Inspection and Service of Components

Drawing 18

Stator

Inspect the trough holes of the Stator (12) to be sure that they are clear.

Drawing 12

Collar O-rings

Inspect the Small and Large Collar O-rings, (3) and (54), for damage (clipped or cut) or deterioration (compression set or hardening) and replace if necessary.

Inspect the Collar-Stem O-ring (55) for damage (clipped or cut) or deterioration (compression set or hardening) and replace if necessary.

Drawings 4-6

Planetary Geartrain Assembly

General Disassembly and Inspection

Tip: Disassemble the Planetary Geartrain Assembly (drawing 6) over a container or a confined space. There are several small components inside of the Geartrain, which may spill out if you are unfamiliar with its contents.

Turn to drawing 6: Pull the Output Shaft (13) and the Input Shaft Lower Bearing Housing (21; drawing 2) from the Planetary Gearhead (drawing 4).

Pull off the top of the Planetary Gearhead (drawing 4) comprised of the Rotor (48; drawing 5), the Input Shaft Upper Bearing Housing (20; drawing 1) and the Input Shaft (39; drawing 3) together. What is left is the cartridge style Gearhead (drawing 4).

If the geartrain O-rings (46) needs to be replaced, remove them at this time. **Warning: To reduce the likelihood of scratching any sealing surface, use a pick made from brass.** Inspect the (46) for damage (clipped or cut) or deterioration (compression set or hardening) and replace as required.

Gearhead Internals

Tip: To prevent the internal components of the Planetary Gearhead from unexpectedly spilling out, make sure that all steps are done with the input side of the assembly facing up.

Using a brass pick or a small screw driver, remove the Internal Retaining Ring (41) and remove the Top Planetary Large Washer (45).

Remove the internal components of the gearhead. Use caution to ensure that no components get lost during this operation. If the internal components are not easily removed, they can be pushed up from the bottom of the gearhead. Also, the other (41) and the Planetary Output Shaft Washer (44) can be carefully removed and the internal components pushed through.

Warning: If you suspect that the Gearhead requires service, proceed with caution. If at any time you do not feel completely comfortable servicing Gearhead, contact Alfa Laval Tank Equipment immediately.

Examine the gears of the four different stages for any worn or broken teeth. Also, examine the Planetary Ring Gear (18) for bent or sharp teeth. If any damage is found, contact Alfa Laval Tank Equipment immediately.

The gears in each level are interchangeable; they all have the same number of teeth.

Drawing 4

Input Shaft and Housings

Take the top of the geartrain that was removed prior in drawing 6. To remove the Rotor (48), grip the outside of the (48) with smooth jaw pliers and use a 5/16" socket to remove the Rotor Nut (5). The Input Pinion (38) can be gripped, but this is not recommended because of the potential of damage to the gear. Only do this if the gear is worn and needs to be replaced.

Ensure that the Carbide (49), pressed into the (48) (drawing 5), protrudes slightly, and is not chipped or cracked.

Check for signs of scoring and wear on the Input Shaft (39; drawing 3). Replace if the coating has been chipped or cracked.

The carbide (49) in the Input Shaft Upper Bearing Housing (20) should protrude slightly out of the top and the second (49) should be recessed 1.32mm (0.052") (drawing 1). In addition, its running surfaces should be smooth, flat, and free of chips and cracks.

5 Maintenance

Read the instructions carefully. The items refer to the parts list and service kits section.

Drawings 2, 6

Input Shaft Lower Bearing Housing and Output Shaft

Inspect the Carbide (49) in the Input Shaft Lower Bearing Housing (21; drawing 2). It should be pressed fully into the (21) and should not be chipped or cracked.

Check for signs of scoring and wear on Output Shaft (13). Replace if the coating has been chipped or cracked.

Drawings 13-15, 17

Nozzle Housing

Unscrew the Nozzles (47) with pliers and inspect for debris caught on the Stream Straightener (36) or in the nozzle orifice. The inside diameter of the (47) must be smooth, round, and free of damage (especially any nicks) for maximum jet impact. Replace worn or oversized nozzles if the original flow rate and pressure are required.

Verify the (36) is tight in the bore of the (47).

Inspect the Nozzle Housing Bevel Gear (16) for wear such as sharp/pointed or worn teeth. If it needs to be replaced, remove the Bevel Gear Retaining Ring (17) with a small slotted screwdriver and pry the (16) from the Nozzle Housing (9).

Clean any deposits from the Nozzle Housing Cups (27) and examine for excessive wear. Light scoring is acceptable, but the (27)s should be replaced if they are grooved in the bearing contact area. A good maintenance program will require replacing many (27)s, therefore, it may be worthwhile to make or obtain press tools for pressing a (27) out of a (9). The press tools are available from Alfa Laval Tank Equipment. Before installing a new (27), clean the housing bores and remove any burrs resulting from (27) removal. Press them in so that their flanges are flush against the (9).

Inspect the Nozzle Housing Bearings (25) and (26). Clean any deposits from the exterior of the (25)/(26) and check their fit in the (27). While they should turn freely, the (25) and/or (26) should be replaced if the thickness of the **flange is 2.18mm (0.086")**, or less, to avoid shortening the life of the Bevel Gears (15) and (16).

Drawings 8, 10, 11

Tee Housing and Tee Housing Cap

Check the water outlets on the nose of the Tee Housing (8); they should be free of debris.

Inspect the Tee Housing Bearings (23). Clean any deposits from the exterior of the (23) and check their fit in the Tee Housing Cups (24). While they should turn freely, a (23) should be replaced if the thickness of the **flange is 2.41mm (0.095")**, or less, to avoid shortening the life of the Bevel Gears (15) and (16).

Inspect the Tee Housing Cap O-ring (3) for compression set or deterioration. Replace, if needed.

Inspect the Tee Housing Bevel Gear (15) for worn, damaged or sharp/pointed teeth.

Ensure that the Bearing Locking Pin (37) is pressed firmly into (15).

Clean any deposits from the (24) and examine for excessive wear. Light scoring is acceptable, but the Cups should be replaced if they are grooved in the bearing contact area. A good maintenance program will require replacing many (24)s, therefore, it may be worthwhile to make or obtain press tools for pressing a (24) out of the (8). The press tools are available from Alfa Laval Tank Equipment. Before installing a new (24), clean the housing bores and remove any burrs resulting from a (24) removal. Press them in so that their flanges are flush against the (8).

Ensure that the (37) is pressed firmly into the (8).

Drawings 7, 9

Stem and Stem Base

The Bearing Locating Pin (37) should be firmly pressed into the Stem Base (22).

Inspect the water outlets of the Stem (7); they should be free of debris.

The Dowel Pins (1) and Tapered Pins (35) should be firmly pressed into the (7).

Check the Clutch O-ring (33) for signs of damage (clipped or cut), deterioration (compression set or hardening) or wear (flat edge developing or ring has thinned) and replace if necessary.

Drawings 7

Clutch to Pin Drive, Pin Drive to Clutch

The Dowel Pin (1) should not be present in the Stem (7) if the machine is a clutch machine. In order to make the machine a pin driven machine, simply push a (1) into its hole in the (7) until it completely stops at the bottom of the hole. The Clutch O-ring (33) remains in place.

Warning: Once a machine is made into a pin drive, the Nozzle Housing (9) will no longer rotate freely. Forcing the Nozzle Housing (9) to rotate will result in damage to the machine.

To make a pin machine into a clutch machine, use a pair of pliers to grip the (1) and pull it out of the (7). If the (1) cannot be pulled out, use a grinder to grind away the exposed portion of the (1); this method will make it harder to return the machine to a pin drive if desired later. The (33) should already be installed and will run as a normal clutch machine.

Read the instructions carefully. The items refer to the parts list and service kits section.

5.5 Reassembly

General Notes

All parts must be cleaned thoroughly before reassembling. Any deposits remaining on the parts can cause difficult disassembly the next time the Alfa Laval Gamajet needs servicing. Also, it may cause misalignment of parts and the potential for premature failure.

Unless otherwise stated, apply a dab of a **Teflon-based anti-seize compound** to all threads when reassembling; this will prevent galling of threads and ease any future disassembly.

To ease installation of all O-rings, they should be lubricated prior to reassembly. Lithium-based soap grease is acceptable, for Viton® O-rings; however, a Silicon based lubricant must be used for EP O-rings. Do not lubricate the Clutch O-ring (33).

Drawings 4, 6

Gear Train

With the empty Planetary Ring Gear (18), replace the Top Planetary Large Washer (45) and the Internal Retaining Ring (41) into the top of the (18). The top is the end with the 4 holes drilled in the sides.

With all the internal components assembled as in (drawing 4), slide the assembly into the (18) from the bottom up. The assembly may need to be jiggled or twisted slightly in order to get the gear teeth to line up.

Note: Ensure that every Planet Gear (30) has a Planet Gear Washer (40) under it on each post.

Replace the Planetary Output Shaft Washer (44) and the (41) on the bottom of the gearhead. This completes the cartridge gearhead assembly.

Place the Output Shaft (13) through the Input Shaft Lower Bearing Housing (21; drawing 2) and press the bottom of the geartrain assembly firmly onto the bottom of the gearhead. Be sure to align the pin on the (21) with the slot on the outside of the (18).

Insert the Input Shaft (39; drawing 3) through the Input Shaft Upper Bearing Housing (20; drawing 1). Put the Rotor (48; drawing 5) over the end of the shaft with the Carbides of the (48) and the (20) facing each other.

Fasten the Rotor Lock Washer (4) and the Rotor Nut (5) onto the top of the (39) and tighten with a 5/16" socket wrench. The (48) can be held with smooth jaw pliers to keep it from rotating. Do not grip the Input Pinion (38) while tightening the (5) because this will cause damage to the gear.

Press the top of the geartrain assembly firmly onto the top of the gearhead ensuring that the (38) aligns with the top layer of planet gears and the Gearbox Pin (2) on the (20) is aligned with the slot on the outside of the Planetary Ring Gear (18).

Drawing 11

Body Assembly

Slide the Tee Housing Bevel Gear (15; drawing 10) over the end of the Stem (7; drawing 7). Align the hole in the (15) with the Dowel Pin (1).

Place the first Tee Housing Bearing (23) onto the (7).

Push the Tee Housing (8; drawing 8) over it until it is fully seated.

Install the second (23) onto the (7).

Tip: Now, place the second Tee Housing Bearing (23) into the Stem Base (22; drawing 9), aligning its hole with the Bearing Locating Pin (37). Now, invert the (8)/(7) assembly and place it over the (23)/(22) assembly. This technique ensures correct alignment of the (23) and (37). Apply pressure to (22) to drive it and the (23) into the (8).

Align the through holes of the (22) with the threaded holes in the top of the (7). Using a 5/32" Hex Key, thread the Stem Screws (32) and Stem Lockwashers (53) into the (7). Tighten in a star pattern.

Thread the Tee Housing Cap (14) to the end of the (8). **Note:** This is a **Left-Hand** thread.

Drawing 12

Geartrain Installation

Insert the Geartrain (drawing 6) from into the Body Assembly (drawing 11). Rotate the Tee Housing (8) until the Output Shaft (13) falls into the slot of the Tee Housing Cap (14). Continue rotating the (8) until the Tapered Pins (35) are between the tabs of the Input Shaft Upper Bearing Housing (20; drawing 1) and the Geartrain (drawing 6) is able to be seated fully down.

Thread the Cap (6) into the Body Assembly (drawing 11). Be sure to use the flats provided on the (6). Tighten.

Warning: Hold or turn on Stem (7). DO NOT hold or turn on Tee Housing (8) or Tee Housing Cap (14). Doing so will damage the Geartrain (drawing 6).

5 Maintenance

Read the instructions carefully. The items refer to the parts list and service kits section.

Drawing 17

Nozzle Housing

Place the Nozzle Housing Lower Bearing (25) onto the nose of the Tee Housing (8). Ensure the Bearing Locking Pin (37) aligns with the hole in the (25).

Push the Nozzle Housing Assembly (drawing 15) onto the nose of the (8).

Rotate the Nozzle Housing Assembly (drawing 15) slightly to mesh the Bevel Gears (15) and (16). Failure to ensure that the (15) and (16) have properly mated could damage them.

Install the Nozzle Housing Upper Bearing (26) into the Nose Plate (10; drawing 16). Ensure the (37) aligns with the hole in the (26). This will hold the (26) during installation and will keep the hole in the (26) to be properly aligned with the (37).

Using a 1/2" slotted screwdriver, screw the (10)/(26) assembly completely snug.

Drawing 18

Completed Assembly

Rotate the Rotor (48) using a Hex Key, screwdriver or thin rod. It should spin easily and its veins must not strike the walls of the Cap (6). Continue turning the (48) several dozen times. The Nozzles (47) and Tee Housing (8) will slowly rotate if everything has been assembled correctly.

Insert the Stator (12) into the (6).

Screw on the Sanitary Inlet (11) (hand-tight only), and tighten the Set Screw (34) with a 3/32" Hex Key.

Warning: Hold or turn on Stem (7). DO NOT hold or turn on Tee Housing (8) or Tee Housing Cap (14). Doing so will damage the Geartrain (drawing 6).

*It is important to observe the technical data during installation, operation and maintenance.
Inform personnel about the technical data.*

6.1 Technical Data

The Alfa Laval GJ PF-FT Tank Cleaning Machine is a highly efficient machine at a range of pressures and flows. The instruction manual is part of the delivery. Read the instruction carefully.

TECHNICAL DATA

Lubricant Self-lubricating with the cleaning fluid
Max. throw length 14 – 20 m (45 - 65 ft.)

Pressure

Working pressure 3 – 28+ bar (40 – 400+ PSI)
Recommended pressure 4 – 20 bar (50 – 300 PSI)

Cleaning Pattern

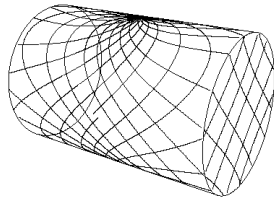

First Cycle

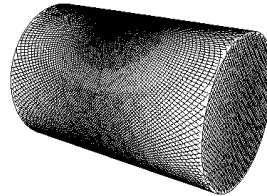

Full Pattern

The above drawings show the cleaning pattern achieved on a cylindrical horizontal vessel. The difference between the first cycle and the full pattern represents the number of additional cycles available to increase the density of the cleaning.

Certificate

2.1 Material Certificate

PHYSICAL DATA

Materials

1.4404 (316L), PPS, FKM, (EPDM and FKM available).

Temperature

Max. working temperature 95°C (203°F)
Max. ambient temperature 140°C (284°F)

Weight 4.3 kg (9.5 lbs.)

Surface finish 0.5 µm (20 Ra)

Connections

Available option 1 ½" weld, 1 ½" tri-clamp, 1 ½" ISO 2037 slip fit, 1 ½" DIN R1 slip fit, 1.5" DIM R2 slip fit
Standard thread 1 ½" Rp (BSP) or NPT, female

Options

Electronic rotation sensor to verify 3D coverage.

Caution

Do not use for gas evacuation or air dispersion.

6 Technical Data

*It is important to observe the technical data during installation, operation and maintenance.
Inform personnel about the technical data.*

6.2 Performance Data

Standard and Low-Profile PF-FT (2-nozzle):

Flow Rate

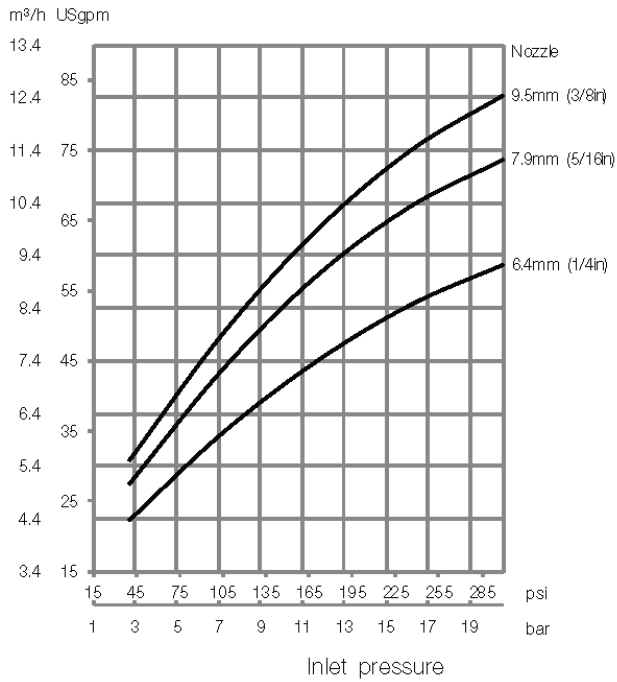

Impact Throw Length

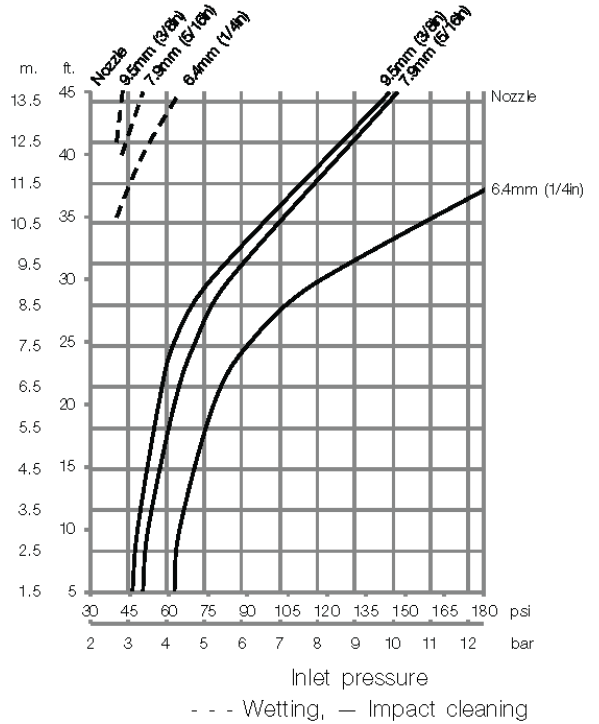

Cleaning Time

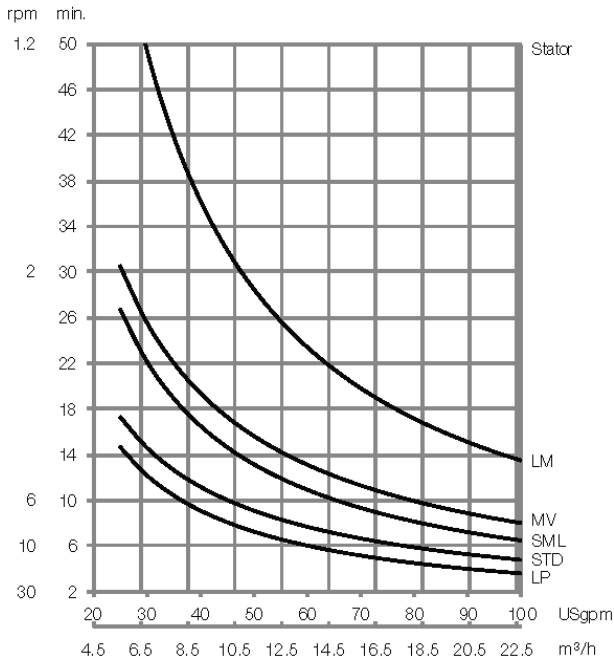

*It is important to observe the technical data during installation, operation and maintenance.
Inform personnel about the technical data.*

Standard and Low-Profile PF-FT (4-nozzle):

Flow Rate

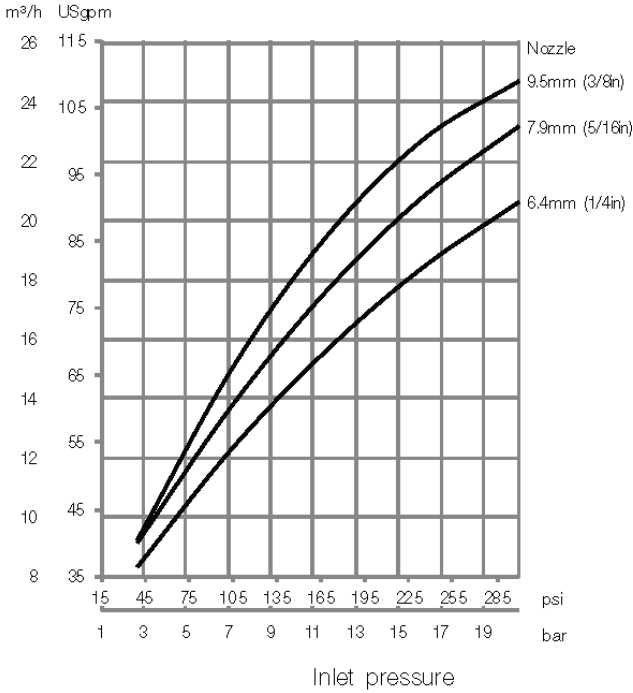

Impact Throw Length

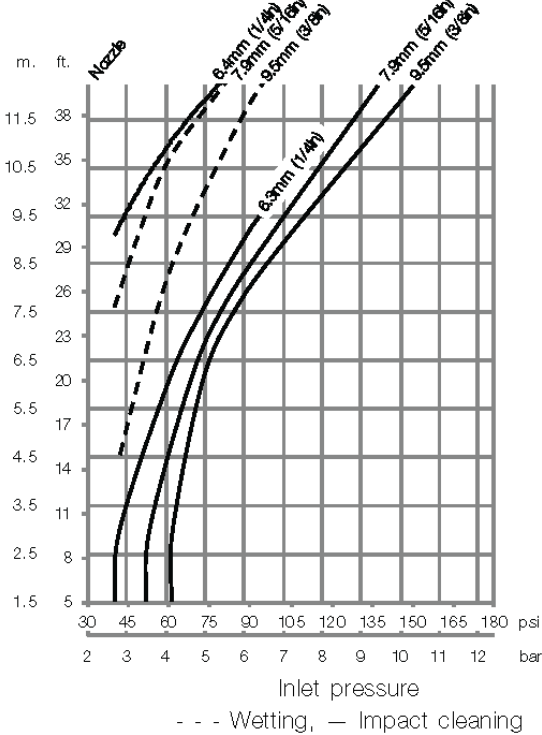

Cleaning Time

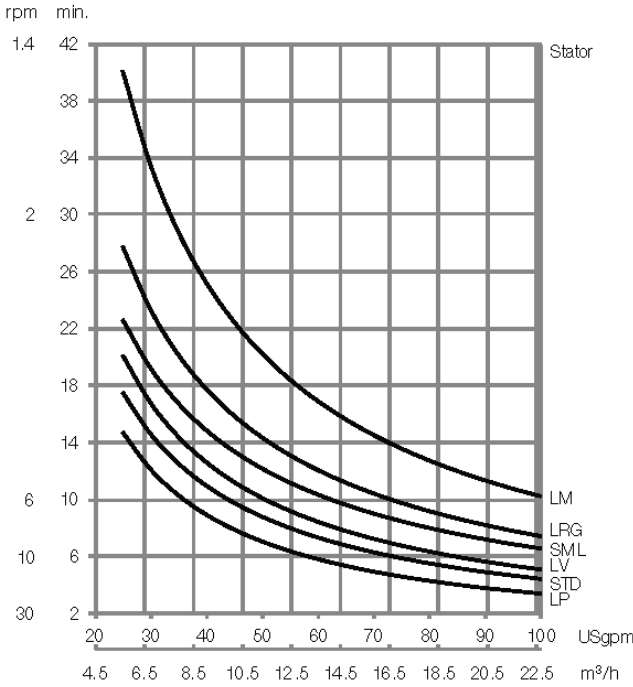

6 Technical Data

*It is important to observe the technical data during installation, operation and maintenance.
Inform personnel about the technical data.*

6.3 Dimensions

PF-FT (2-nozzle):

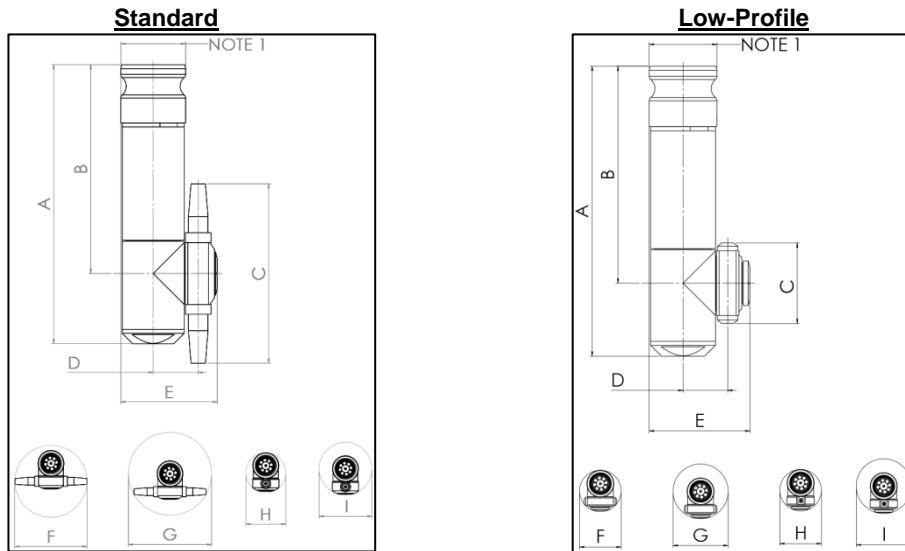

Standard:

	A	B	C	D	E	F	G	H	I
mm	272	204	175	44	94	176	202	98	129
in	10.70	8.01	6.88	1.73	3.69	6.90	7.95	3.83	5.05

NOTE: 1-1/2" FNPT/2" CAMLOCK OR 1-1/2" BSP/2" CAMLOCK

Low-Profile:

	A	B	C	D	E	F	G	H	I
mm	272	204	76	42	94	97	129	97	129
in	10.70	8.01	2.98	1.64	3.69	3.82	5.05	3.82	5.05

NOTE: 1-1/2" FNPT/2" CAMLOCK OR 1-1/2" BSP/2" CAMLOCK

PF-FT (4-nozzle):

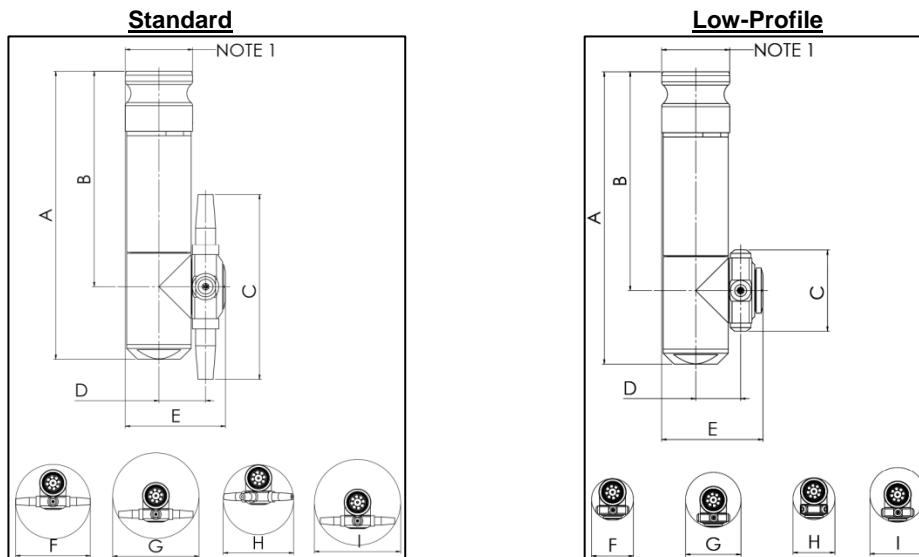

Standard:

	A	B	C	D	E	F	G	H	I
mm	272	204	175	44	94	176	202	165	202
in	10.7	8.01	6.88	1.73	3.69	6.90	7.95	6.48	7.95

NOTE: 1-1/2" FNPT/2" CAMLOCK OR 1-1/2" BSP/2" CAMLOCK

Low-Profile:

	A	B	C	D	E	F	G	H	I
mm	272	204	76	42	94	97	129	97	129
in	10.70	8.01	2.98	1.64	3.69	3.82	5.05	3.82	5.05

NOTE: 1-1/2" FNPT/2" CAMLOCK OR 1-1/2" BSP/2" CAMLOCK

*It is important to observe the technical data during installation, operation and maintenance.
Inform personnel about the technical data.*

6.4 Trax Simulation Tool

Standard Design

The choice of nozzle diameters can optimize jet impact length and flow rate at the desired pressure. As standard documentation, the Alfa Laval GJ PF-FT can be supplied with a “Declaration of Conformity” for material specifications.

TRAX Simulation Tool

TRAX is a unique software that simulates how the Alfa Laval GJ PF-FT performs in a specific tank or vessel. The simulation gives information on wetting intensity, pattern mesh width and cleaning jet velocity. This information is used to determine the best location of the tank cleaning device and the correct combination of flow, time, and pressure to implement.

A TRAX demo containing different cleaning simulations covering a variety of applications can be used as a reference and documentation for tank cleaning applications. The TRAX demo is free and available upon request.

**2-Nozzle:
Wetting Intensity**

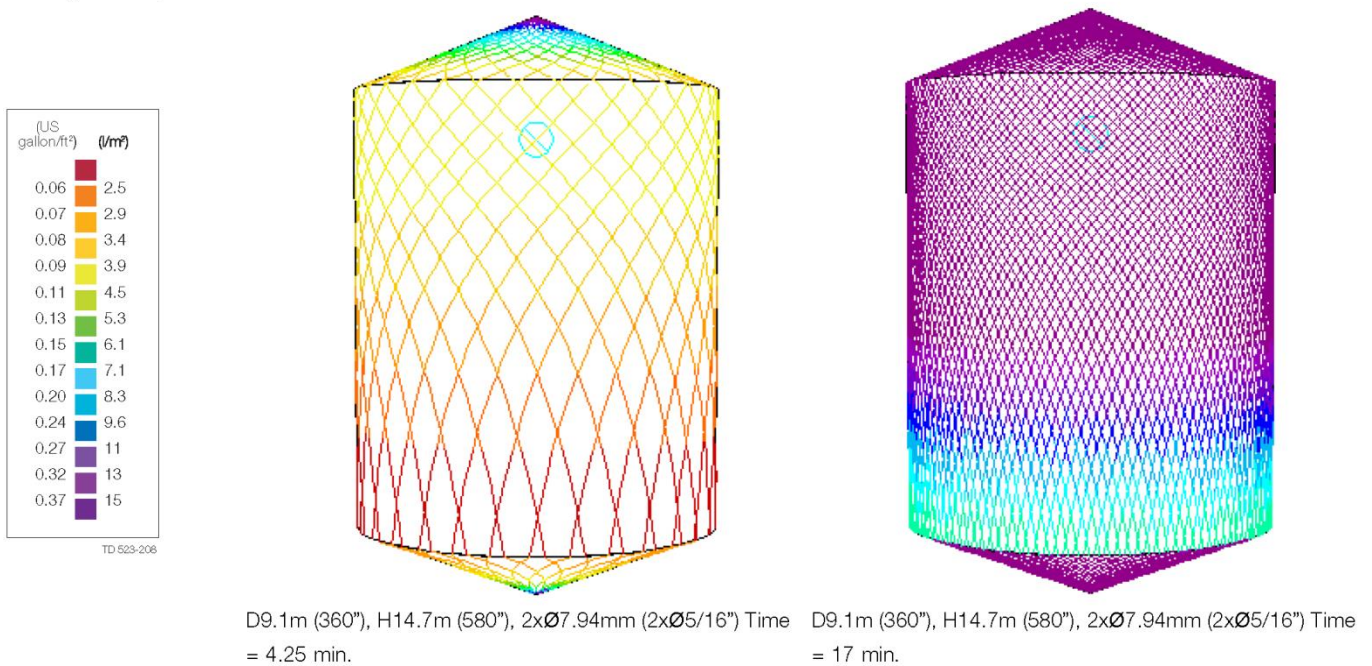

**4-Nozzle:
Wetting Intensity**

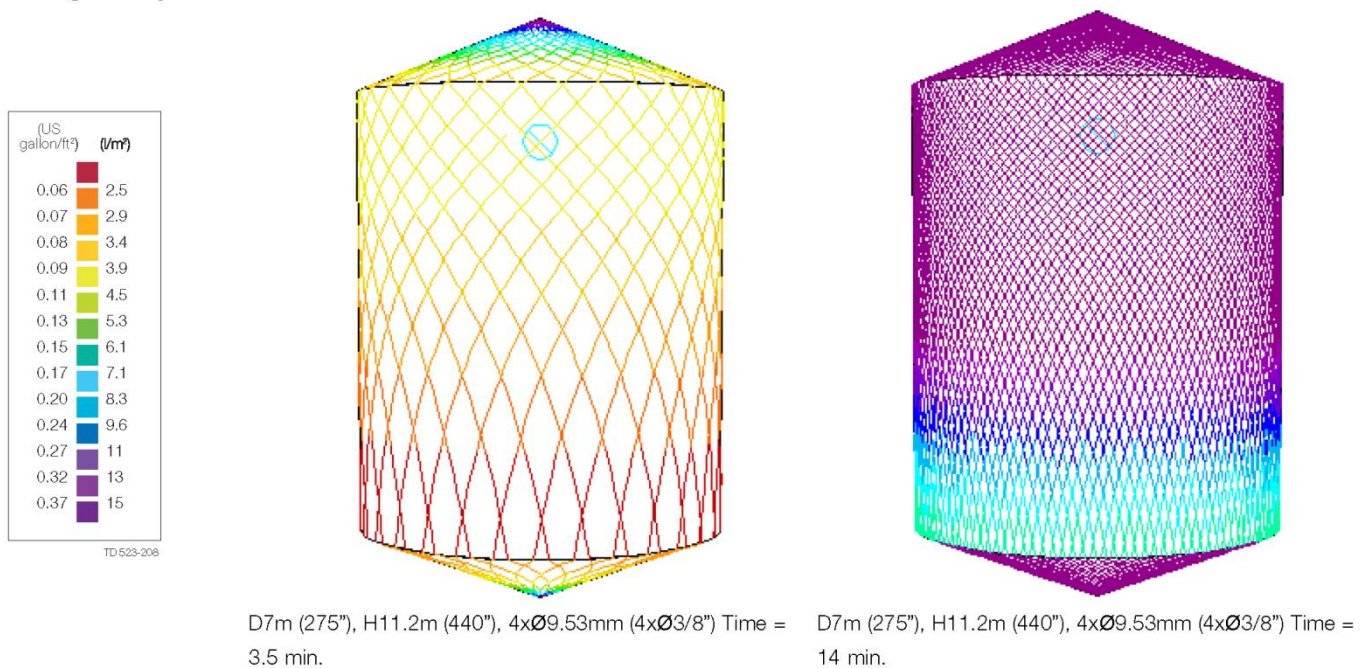

7 Parts List and Service Kits

The Drawing shows Alfa Laval GJ PF-FT Tank Cleaning Machine

7.1 AL GJ PF-FT View

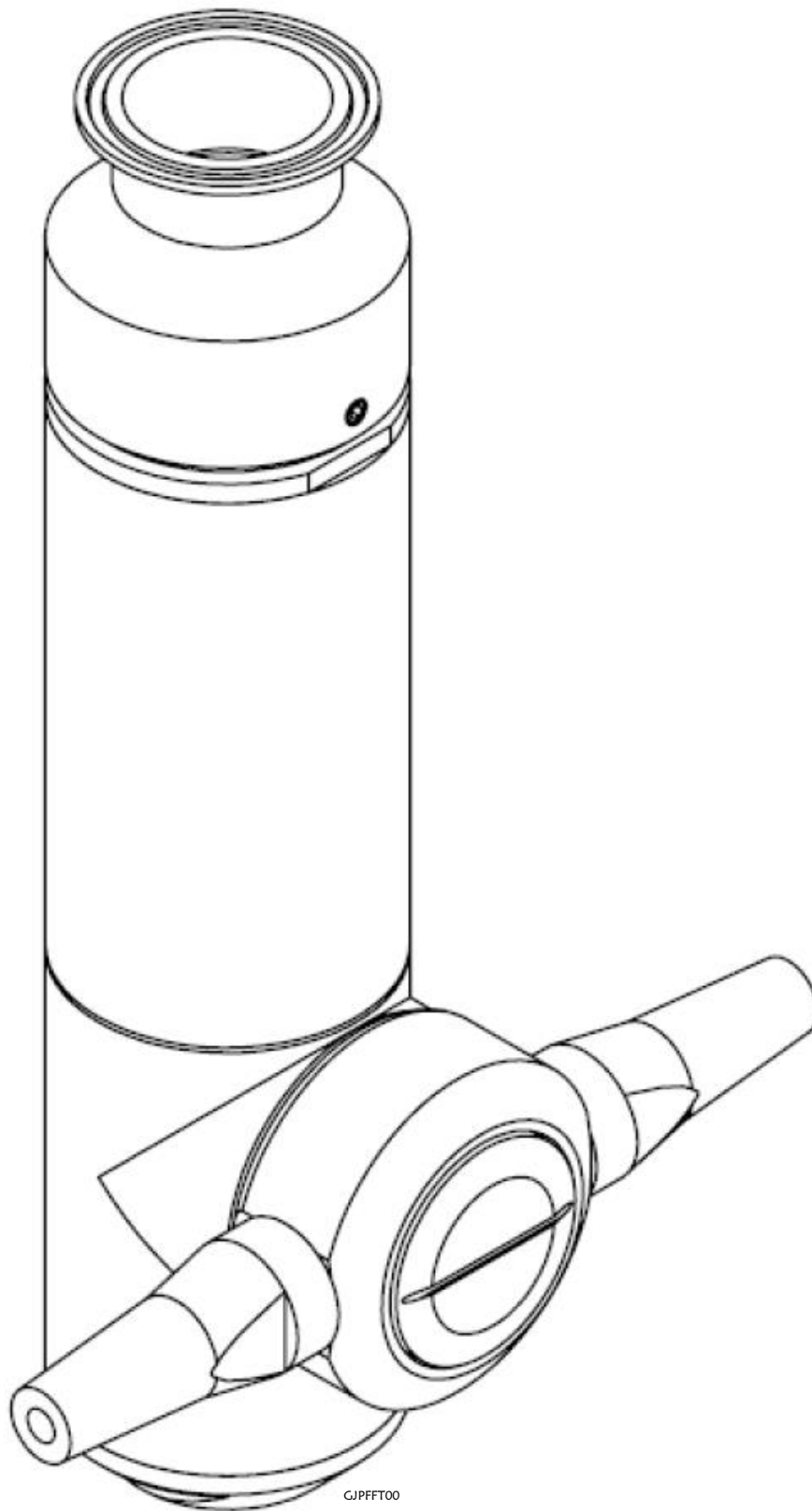

7.2 Assembly Drawings – 1, 2 & 3

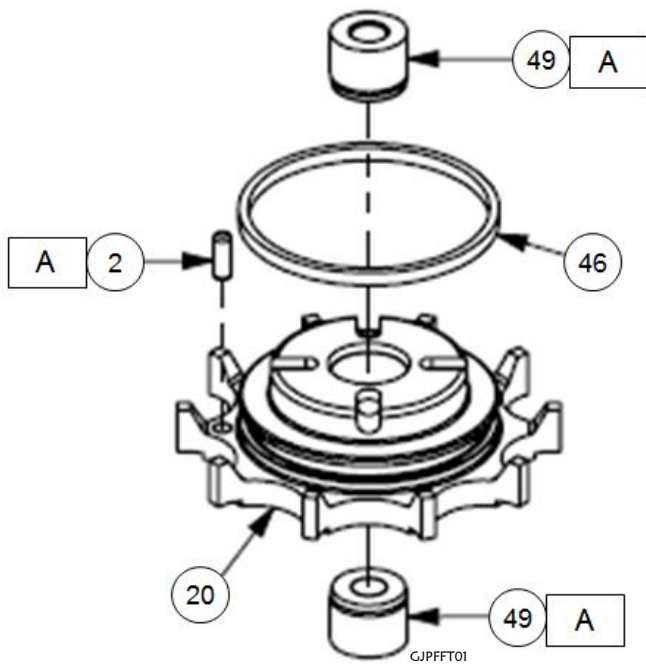

Drawing 1 – Input Shaft Upper Bearing Housing

A: Press Fit

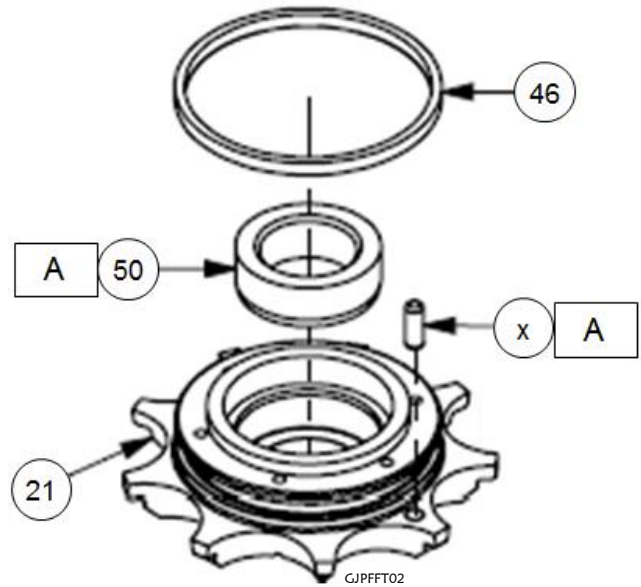

Drawing 2 – Input Shaft Lower Bearing Housing

A: Press Fit

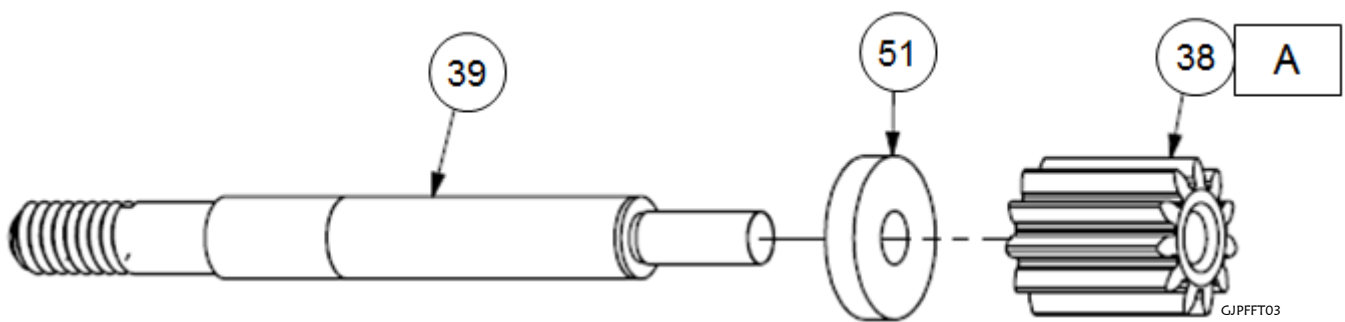

Drawing 3 – Input Shaft

A: Press Fit

Note: The (38) must be completely perpendicular to the (39) or it will not press on correctly and damage the (38) or (39)

7 Parts List and Service Kits

The Drawing shows Alfa Laval GJ PF-FT Tank Cleaning Machine

7.3 Assembly Drawing – 4

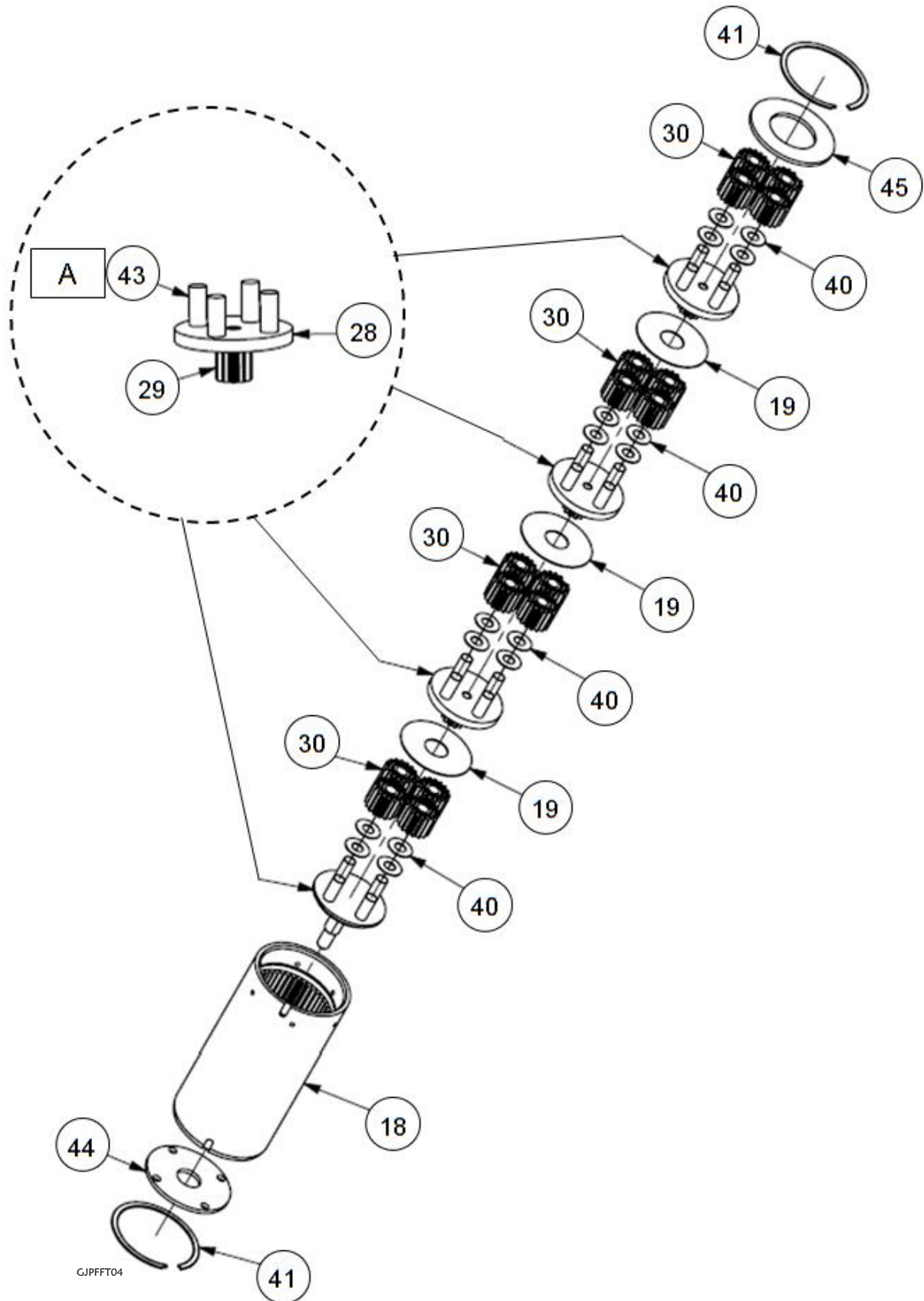

Drawing 4 – Gearhead

A: Press Fit

7.4 Assembly Drawings – 5 & 6

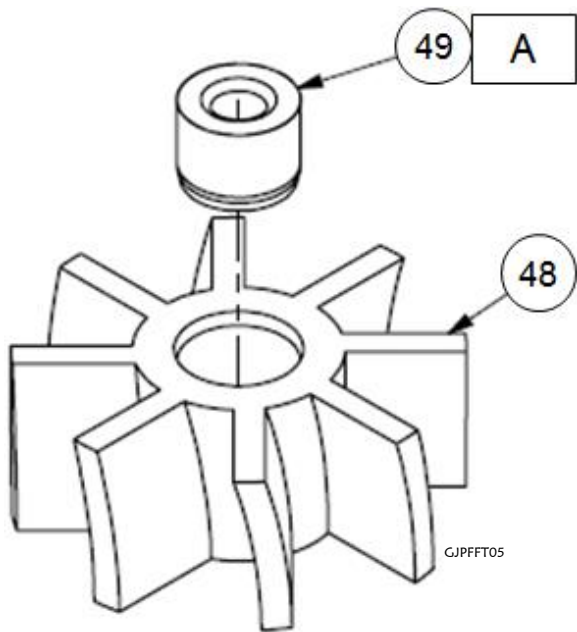

Drawing 5 – Rotor

A: Press Fit

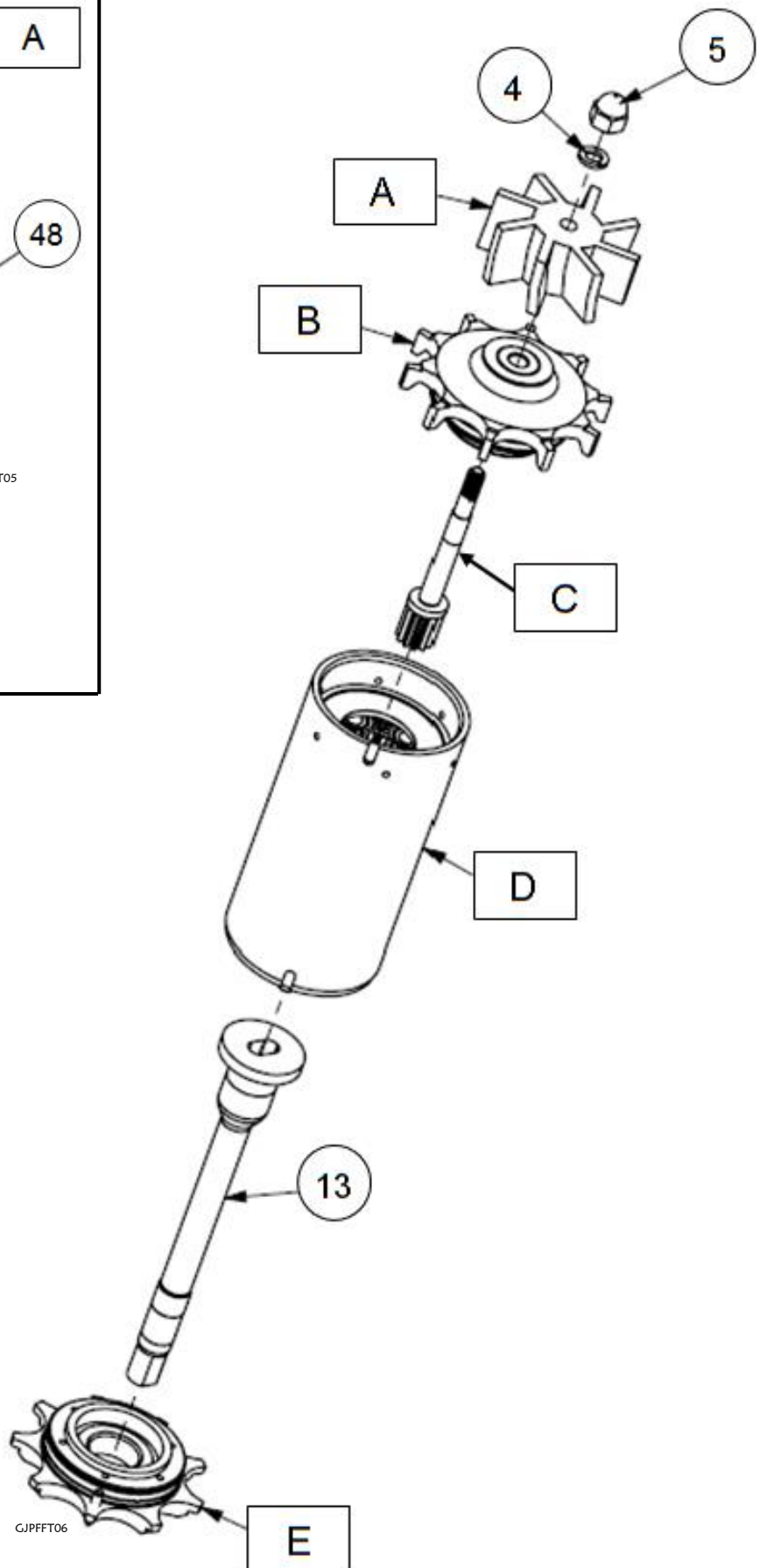

Drawing 6 - Geartrain

- A: Drawing 5
- B: Drawing 1
- C: Drawing 3
- D: Drawing 4
- E: Drawing 2

7 Parts List and Service Kits

The Drawing shows Alfa Laval GJ PF-FT Tank Cleaning Machine

7.5 Assembly Drawings – 7, 8, 9, 10 & 11

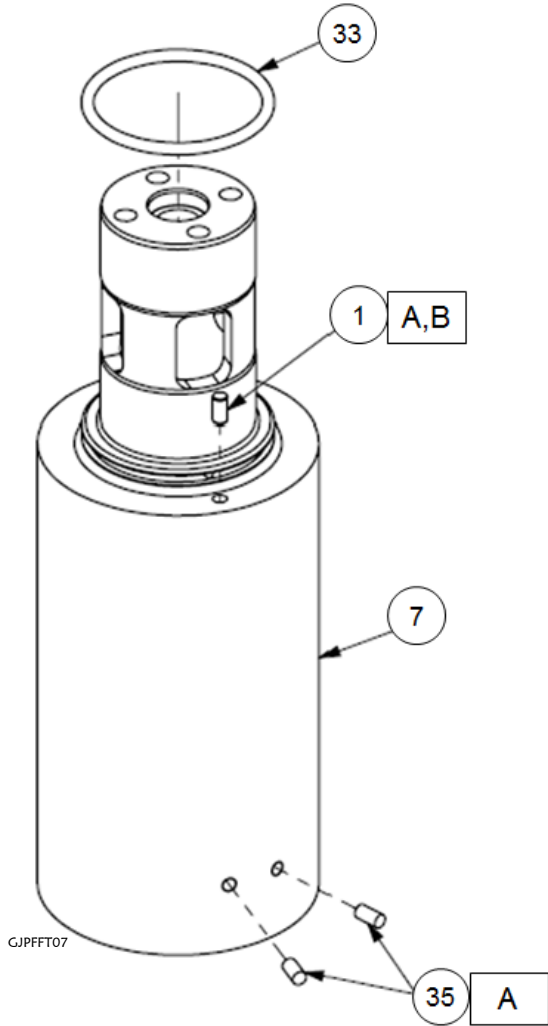

Drawing 7 – Stem

A: Press Fit
B: Used for Pin Drive Machines Only

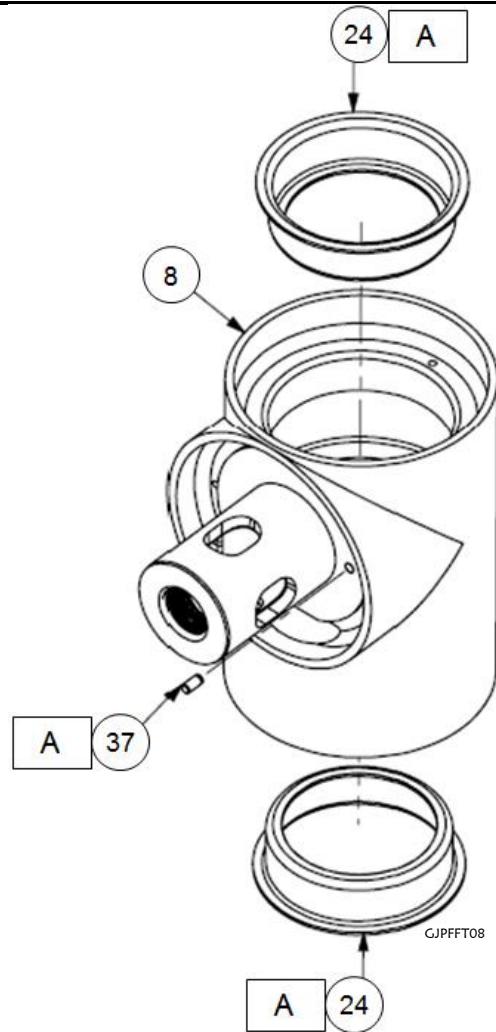

Drawing 8 – Tee Housing

A: Press Fit

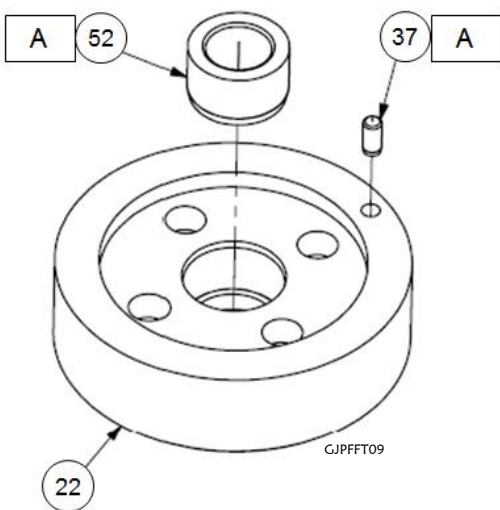

Drawing 9 – Stem Base

A: Press Fit

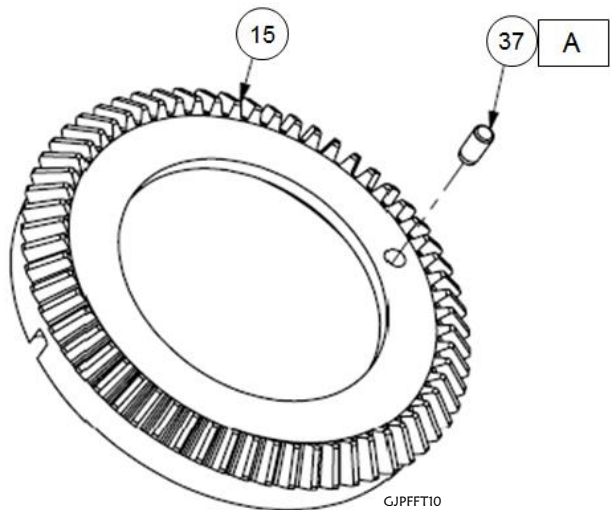

Drawing 10 – Tee Housing Bevel Gear

A: Press Fit

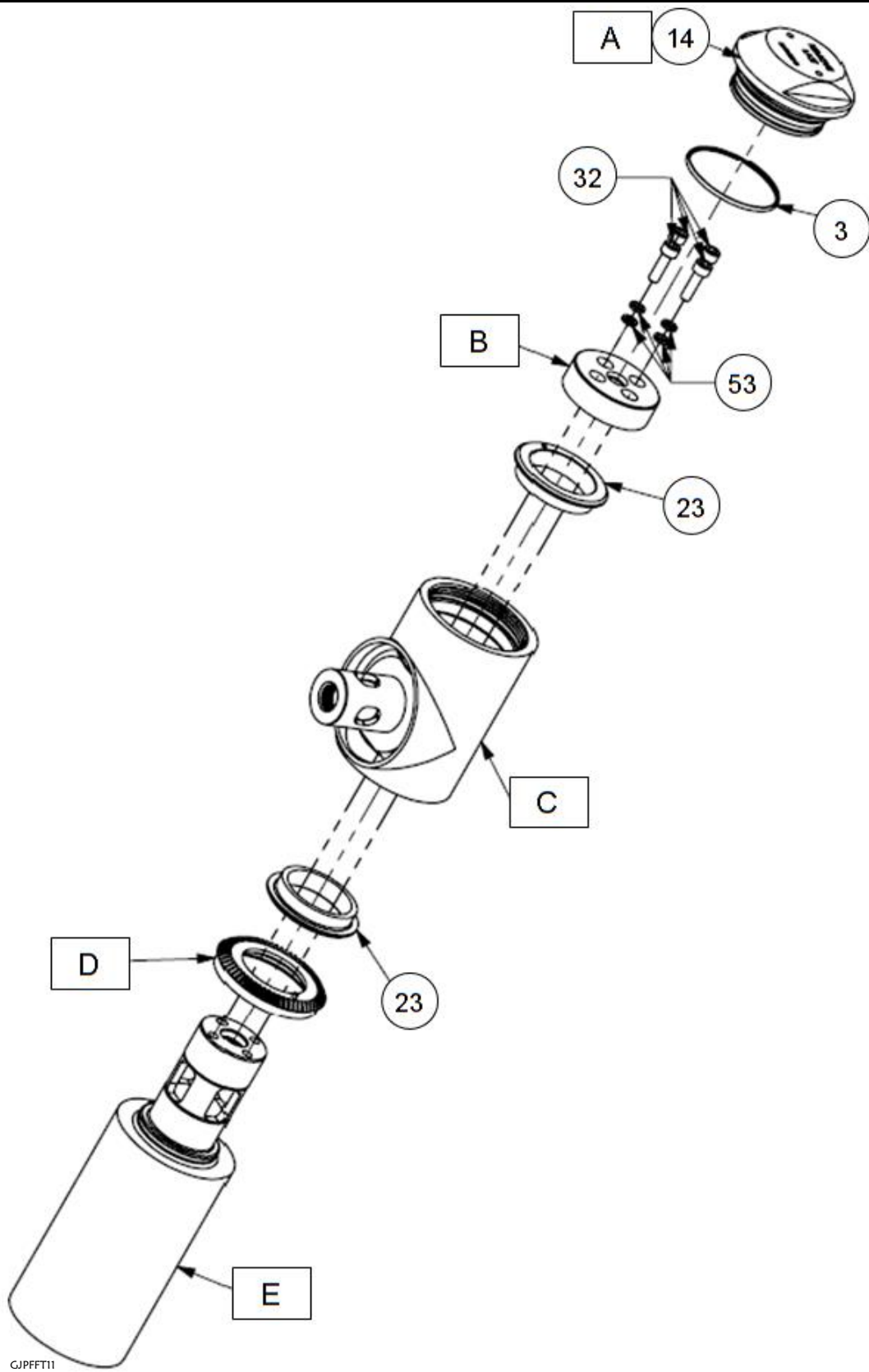

Drawing 11 – Body Assembly

A: Left-Handed Thread
C: Drawing 8
E: Drawing 7

B: Drawing 9
D: Drawing 10

7 Parts List and Service Kits

The Drawing shows Alfa Laval GJ PF-FT Tank Cleaning Machine

7.6 Assembly Drawing – 12

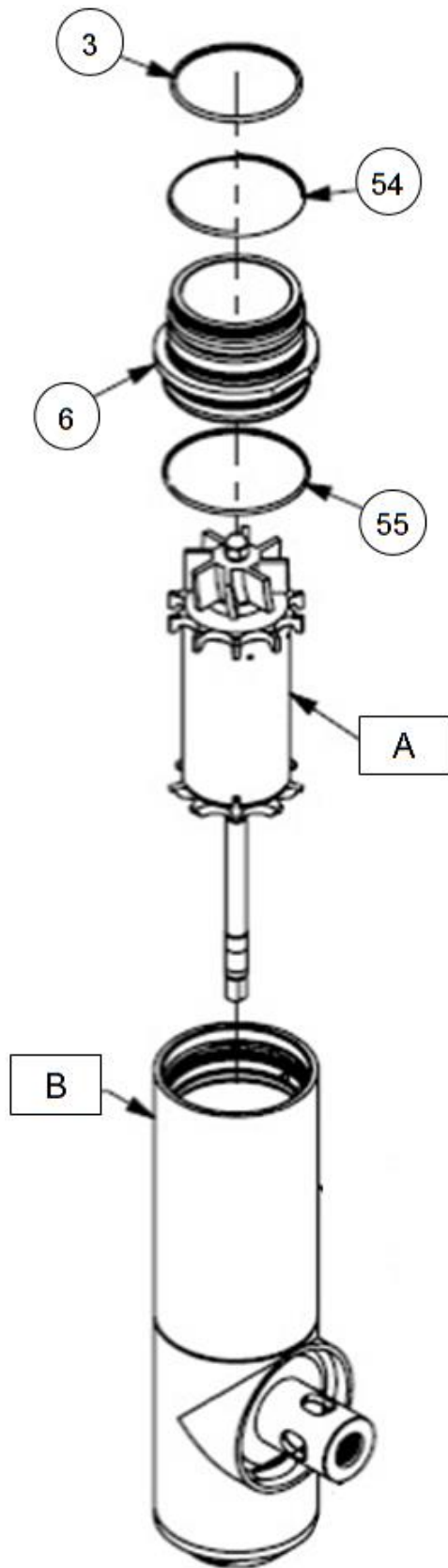

Drawing 12 – Install Geartrain and Cap

GJPF12

A: Drawing 6
B: Drawing 11

7.7 Assembly Drawings – 13, 14, 15, 16 & 17

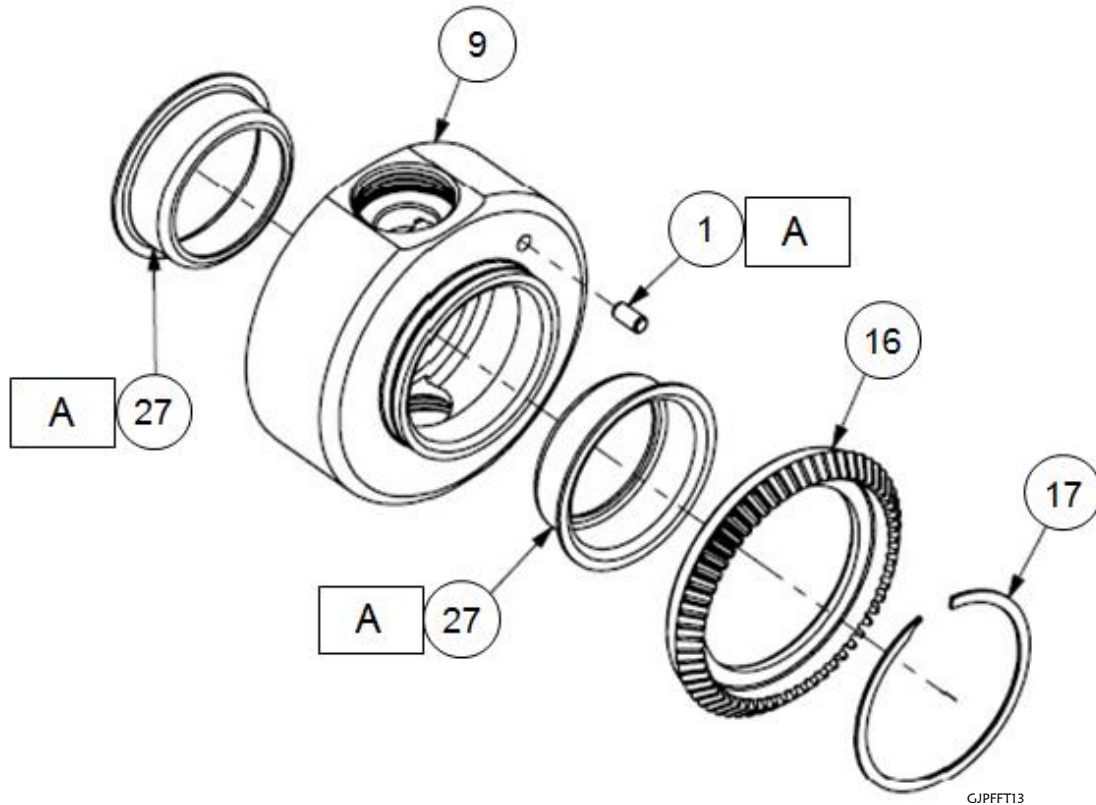

Drawing 19 – Nozzle Housing Assembly

A: Drawing 18

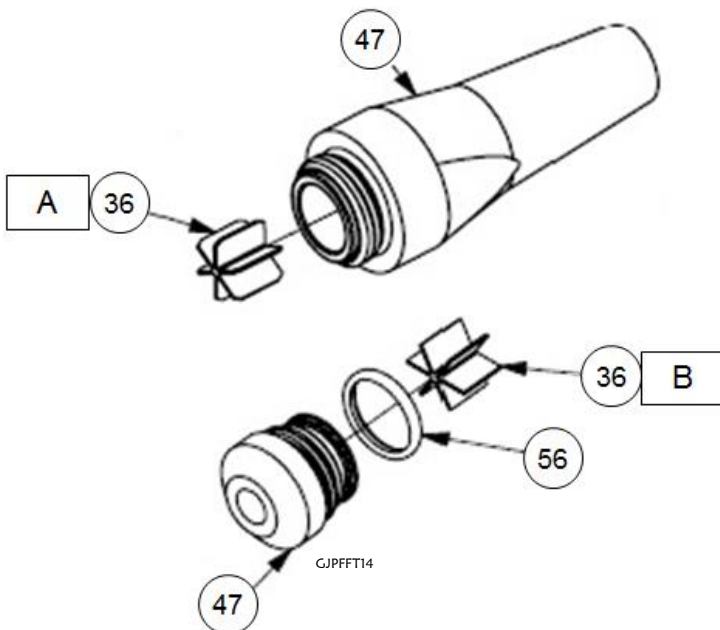

Drawing 14 – Nozzles (Top: Standard; Bottom: Low Profile)

A: Press flush with bottom edge.
 B: Part will protrude when installed. Press until part bottoms out.

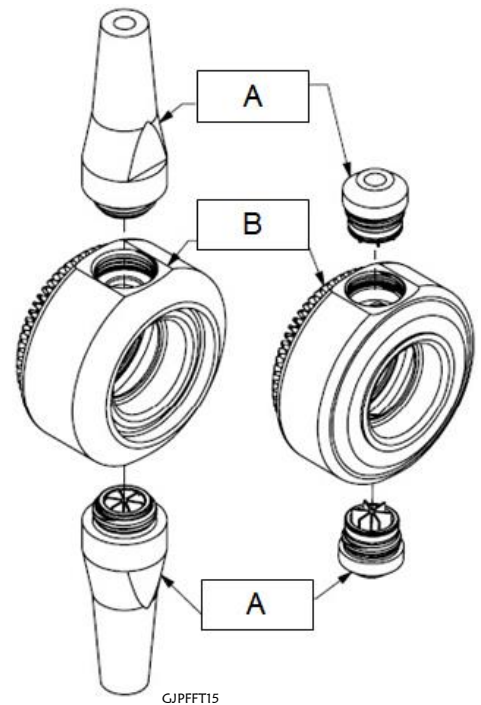

Drawing 15 – Nozzle Housing

A: Drawing 14
 B: Drawing 13

7 Parts List and Service Kits

The Drawing shows Alfa Laval GJ PF-FT Tank Cleaning Machine

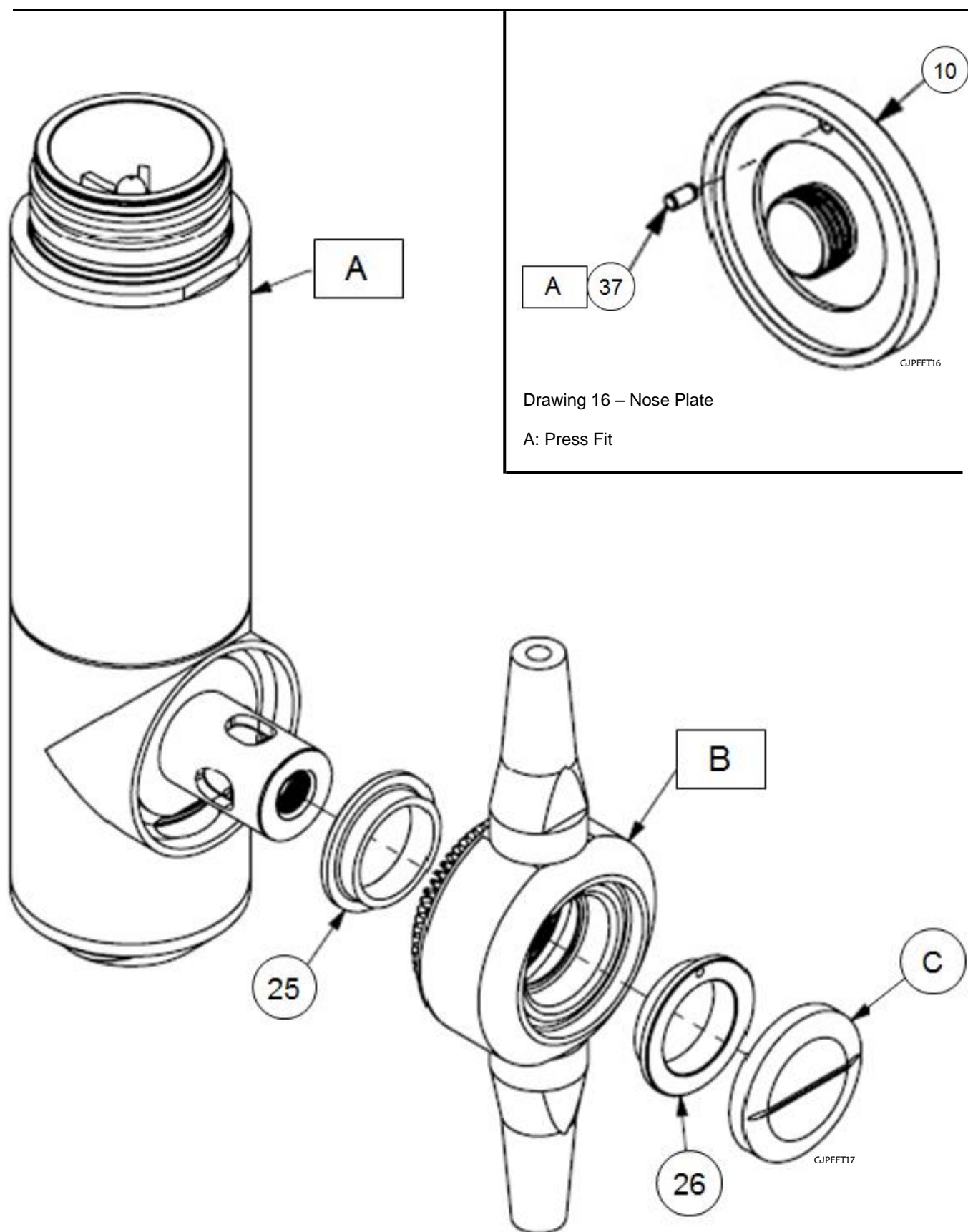

Drawing 17 – Install Nozzle Housing

A: Drawing 12
B: Drawing 15
C: Drawing 16

7.8 Assembly Drawing – 18

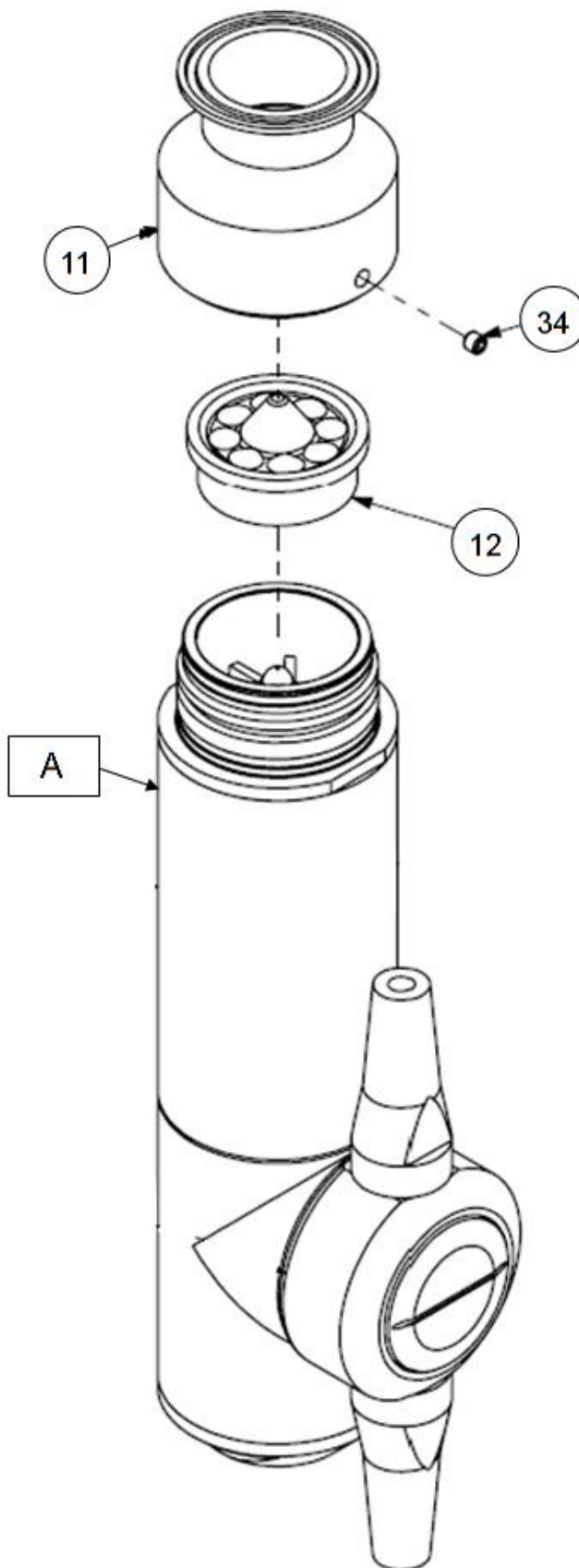

Drawing 18 – Completed Assembly

A: Drawing 17

7 Parts List and Service Kits

7.9 Parts List

Pos.	AL No.	Gamajet No.	Description	No.
1	9614611101	E-866	Dowel Pin	2
2	9614627801	6-166	Gearbox Pin	2
3.1	9614636801	7-458- E	Small Collar & Tee Housing Cap O-ring - EPDM	2
3.2	9614636802	7-458-K	Small Collar & Tee Housing Cap O-ring – Kalrez	2
3.3	9614636803	7-458-V	Small Collar & Tee Housing Cap O-ring - Viton	2
4	9614678201	8-544	Rotor Lockwasher	1
5	9614678301	8-545	Rotor Nut	1
6	9614641101	10-102	Cap	1
7	9614641301	10-103-PF	Stem	1
8	9614641601	10-104-PF-FT	Tee Housing	1
9.1	9614641901	10-105-PF	Nozzle Housing	1
9.2	9614641801	10-105-D-LP	Dual Nozzle Low Profile Housing	1
9.3	9614642001	10-105-Q-LP	Quad Nozzle Low Profile Housing	1
10	9614642301	10-106-FT	Nose Plate	1
11	9614642704	10-108-S	1-1/2" Sanitary Inlet	1
12.1	9614642805	10-109-STD	Stator – STD	1
12.2	9614642803	10-109-LP	Stator – LP	1
12.3	9614605003	E-809-LV	Stator – LV	1
12.4	9614642802	10-109-LM	Stator – LM	1
12.5	9614642804	10-109-MV	Stator – MV	1
12.6	9614605009	E-809-SML	Stator – SML	1
12.7	9614605002	E-809-LRG	Stator – LRG	1
12.8	9614642801	10-109-HV	Stator – HV	1
13	9614643001	10-112-F	Output Shaft	1
14	9614643401	10-114-PF	Tee Housing Cap	1
15	9614643501	10-117	Tee Housing Bevel Gear	1
16	9614643601	10-118	Nozzle Housing Bevel Gear	1
17	9614643701	10-119	Bevel Gear Retaining Ring	1
18	9614643901	10-125	Planetary Ring Gear	1
19	9614644001	10-126	Planetary Large Washer	3
20	9614644201	10-128-F	Input Shaft Upper Bearing Housing	1
21	9614644401	10-129-F	Input Shaft Lower Bearing Housing	1
22	9614644501	10-130	Stem Base	1
23	9614644701	10-131-FT	Tee Housing Bearing	2
24	9614644801	10-132	Tee Housing Cup	2
25	9614644901	10-133	Nozzle Housing Lower Bearing	1
26	9614645001	10-133-PF	Nozzle Housing Upper Bearing	1
27	9614645301	10-134	Nozzle Housing Cup	2
28	9614645801	10-137	11 Tooth Planet Gear Carrier	3
29	9614645901	10-138	Pinion Gear, 8 Tooth	3
30	9614646001	10-139	Planet Gear	16
31	9614646101	10-141	Planetary Gear Output Shaft	1
32	9614646201	10-146	Stem Screw	4
33.1	9614646301	10-147	Clutch O-ring - Viton	1
33.2	9614646401	10-147-E	Clutch O-ring – EPDM	1
33.3	9614646501	10-147-K	Clutch O-ring – Kalrez	1
34	9614646601	10-150	Set Screw	1
35	9614647101	10-155	Tapered Pin	2
36	9614647201	10-160	Stream Straightener	2,4
37	9614647501	10-164	Bearing Locating Pin	4
38	9614647701	10-512	Input Pinion	1
39	9614647801	10-822-FT	Input Shaft	1
40	9614647901	10-896	Planet Gear Washer	16
41	9614601301	E-121	Internal Retaining Ring	2
42	9614601601	E-127	Planet Gear Bushing	16
43	9614601901	E-130	Planet Gear Idler Shaft	16
44	9614602201	E-140	Planetary Output Shaft Washer	1
45	9614602501	E-170	Top Planetary Large Washer	1
46.1	9614602701	E-175	O-ring – EPDM	2
46.2	9614602702	E-175-K	O-ring – Kalrez	2
46.3	9614602703	E-175-V	O-ring – Viton	2

Pos.	AL No.	Gamajet No.	Description	No.
47.1	9614604701	E-807-PF -1/4	Powerflex or Low-Profile Nozzle	2,4
47.2	9614604702	E-807-PF-3/8	Powerflex Nozzle	2,4
47.3	9614604703	E-807-PF-5/16	Powerflex Nozzle	2,4
47.4	9614642601	10-107-LP-.25	Low-Profile Nozzle	2,4
47.5	9614642602	10-107-LP-.312	Low-Profile Nozzle	2,4
47.6	9614642603	10-107-LP-.375	Low-Profile Nozzle	2,4
48	9614605101	E-810	Rotor	1
49	9614609101	E-839	Input Shaft Carbide	3
50	9614609201	E-840	Output Shaft Upper Carbide Bushing	1
51	9614609301	E-841	Input Shaft Carbide Thrust Washer	1
52	9614609401	E-842	Output Shaft Lower Carbide Bearing	1
53	9614609801	E-847	Stem & Taper Cap Screw Lockwasher	4
54.1	9614610801	E-862	Large Collar O-ring – Viton	1
54.2	9614610802	E-862-E	Large Collar O-ring – EPDM	1
54.3	9614610803	E-862-K	Large Collar O-ring – Kalrez	1
54.4	9614610804	E-862-T	Large Collar O-ring - Teflon	1
55.1	9614610901	E-863	Collar-Stem O-ring – Viton	1
55.2	9614610902	E-863-E	Collar-Stem O-ring – EPDM	1
55.3	9614610903	E-863-K	Collar-Stem O-ring – Kalrez	1
55.4	9614610904	E-863-T	Collar-Stem O-ring - Teflon	1
56	9614662102	643	Low-Profile Nozzle O-ring	2,4

7 Parts List and Service Kits

7.10 Minor Service Kit

Article no: 9614650501 10PFFTEPDMKIT ALFA LAVAL GAMAJET FT PF KIT - EPDM				
Pos. no.	Part No.	Gamajet Part No.	Description	No.
23	9614644701	10131FT	GJ PF FT TEE HOUSING BEARING	2 pcs.
26	9614645001	10133PF	GJ PF NOZZLE HOUSING BEARING	2 pcs.
33.2	9614646401	10147E	GJ PF CLUTCH O-RING	1 pcs.
54.2	9614610802	E862E	GJ VIII COLLAR STEM SM O-RING	1 pcs.
55.2	9614610902	E863E	GJ VIII COLLAR STEM LG O-RING	1 pcs.
3.1	9614636801	7458	HOUSING O-RING	2 pcs.
19	9614644001	10126	GJ PF FT PLANETARY WASHER	3 pcs.
40	9614647901	10896	GJ PF FT PLANET GEAR WASHER	16 pcs.
42	9614601601	E127	PLANET GEAR BUSHING	16 pcs.
46.1	9614602701	E175	GEARHEAD O-RING - EPDM	2 pcs.

Article no: 9614650901 10PFFTKALKIT ALFA LAVAL GAMAJET FT PF KIT - KALREZ				
Pos. no.	Part No.	Gamajet Part No.	Description	No.
23	9614644701	10131FT	GJ PF FT TEE HOUSING BEARING	2 pcs.
26	9614645001	10133PF	GJ PF NOZZLE HOUSING BEARING	2 pcs.
33.3	9614646501	10147K	GJ PF CLUTCH O-RING	1 pcs.
54.3	9614610803	E862K	GJ VIII COLLAR STEM SM O-RING	1 pcs.
55.3	9614610903	E863K	GJ VIII COLLAR STEM LG O-RING	1 pcs.
3.2	9614636802	7458K	HOUSING O-RING/COLLAR O-RING	2 pcs.
19	9614644001	10126	GJ PF FT PLANETARY WASHER	3 pcs.
40	9614647901	10896	GJ PF FT PLANET GEAR WASHER	16 pcs.
42	9614601601	E127	PLANET GEAR BUSHING	16 pcs.
46.2	9614602702	E175K	GEARHEAD O-RING - KALREZ	2 pcs.

Article no: 9614650701 10PFFTVITKIT ALFA LAVAL GAMAJET FT PF KIT - VITON				
Pos. no.	Part No.	Gamajet Part No.	Description	No.
23	9614644701	10131FT	GJ PF FT TEE HOUSING BEARING	2 pcs.
26	9614645001	10133PF	GJ PF NOZZLE HOUSING BEARING	2 pcs.
33.1	9614646301	10147	GJ PF CLUTCH O-RING	1 pcs.
54.1	9614610801	E862	GJ VIII COLLAR STEM SM O-RING	1 pcs.
55.1	9614610901	E863	GJ VIII COLLAR STEM LG O-RING	1 pcs.
3.3	9614636803	7458V	HOUSING O-RING/COLLAR O-RING	2 pcs.
19	9614644001	10126	GJ PF FT PLANETARY WASHER	3 pcs.
40	9614647901	10896	GJ PF FT PLANET GEAR WASHER	16 pcs.
42	9614601601	E127	PLANET GEAR BUSHING	16 pcs.
46.3	9614602703	E175V	GEARHEAD O-RING - VITON	2 pcs.

7.11 Major Service Kit

Article no: 9614650601 10PFFTEPDMMAJ ALFA LAVAL GAMAJET FT PF MAJOR KIT - EPDM				
Pos. no.	Part No.	Gamajet Part No.	Description	No.
23	9614644701	10131FT	GJ PF FT TEE HOUSING BEARING	2 pcs.
26	9614645001	10133PF	GJ PF NOZZLE HOUSING BEARING	2 pcs.
33.2	9614646401	10147E	GJ PF CLUTCH O-RING	1 pcs.
54.2	9614610802	E862E	GJ VIII COLLAR STEM SM O-RING	1 pcs.
55.2	9614610902	E863E	GJ VIII COLLAR STEM LG O-RING	1 pcs.
3.1	9614636801	7458	HOUSING O-RING	2 pcs.
19	9614644001	10126	GJ PF FT PLANETARY WASHER	3 pcs.
40	9614647901	10896	GJ PF FT PLANET GEAR WASHER	16 pcs.
42	9614601601	E127	PLANET GEAR BUSHING	16 pcs.
46.1	9614602701	E175	GEARHEAD O-RING - EPDM	2 pcs.
13	9614643001	10112F	GJ PF FT OUTPUT SHAFT	1 pcs.
	9614643201	10113FT	GJ FT POWERFLEX GEARHEAD	1 pcs.
24	9614644801	10132	GJ 10 TEE HOUSING CUP	2 pcs.
27	9614645301	10134	GJ 10 NOZZLE HOUSING CUP	2 pcs.
38	9614647701	10512	GJ PF FT INPUT SHAFT	1 pcs.
39	9614647801	10822FT	GJ PF FT ROTOR SHAFT	1 pcs.
51	9614609301	E841	GJ VIII RS CARBIDE THRST WASH	1 pcs.

Article no: 9614651001 10PFFTKALMAJ ALFA LAVAL GAMAJET FT PF MAJOR KIT - KALREZ				
Pos. no.	Part No.	Gamajet Part No.	Description	No.
23	9614644701	10131FT	GJ PF FT TEE HOUSING BEARING	2 pcs.
26	9614645001	10133PF	GJ PF NOZZLE HOUSING BEARING	2 pcs.
33.3	9614646501	10147K	GJ PF CLUTCH O-RING	1 pcs.
54.3	9614610803	E862K	GJ VIII COLLAR STEM SM O-RING	1 pcs.
55.3	9614610903	E863K	GJ VIII COLLAR STEM LG O-RING	1 pcs.
3.2	9614636802	7458K	HOUSING O-RING/COLLAR O-RING	2 pcs.
19	9614644001	10126	GJ PF FT PLANETARY WASHER	3 pcs.
40	9614647901	10896	GJ PF FT PLANET GEAR WASHER	16 pcs.
42	9614601601	E127	PLANET GEAR BUSHING	16 pcs.
46.2	9614602702	E175K	GEARHEAD O-RING - KALREZ	2 pcs.
13	9614643001	10112F	GJ PF FT OUTPUT SHAFT	1 pcs.
	9614643201	10113FT	GJ FT POWERFLEX GEARHEAD	1 pcs.
24	9614644801	10132	GJ 10 TEE HOUSING CUP	2 pcs.
27	9614645301	10134	GJ 10 NOZZLE HOUSING CUP	2 pcs.
38	9614647701	10512	GJ PF FT INPUT SHAFT	1 pcs.
39	9614647801	10822FT	GJ PF FT ROTOR SHAFT	1 pcs.
51	9614609301	E841	GJ VIII RS CARBIDE THRST WASH	1 pcs.

7 Parts List and Service Kits

Article no: 9614650801 10PFFTUITMAJ ALFA LAVAL GAMAJET FT PF MAJOR KIT VITON				
Pos. no.	Part No.	Gamajet Part No.	Description	No.
23	9614644701	10131FT	GJ PF FT TEE HOUSING BEARING	2 pcs.
26	9614645001	10133PF	GJ PF NOZZLE HOUSING BEARING	2 pcs.
33.1	9614646301	10147	GJ PF CLUTCH O-RING	1 pcs.
54.1	9614610801	E862	GJ VIII COLLAR STEM SM O-RING	1 pcs.
55.1	9614610901	E863	GJ VIII COLLAR STEM LG O-RING	1 pcs.
3.3	9614636803	7458V	HOUSING O-RING/COLLAR O-RING	2 pcs.
19	9614644001	10126	GJ PF FT PLANETARY WASHER	3 pcs.
40	9614647901	10896	GJ PF FT PLANET GEAR WASHER	16 pcs.
42	9614601601	E127	PLANET GEAR BUSHING	16 pcs.
46.3	9614602703	E175V	GEARHEAD O-RING - VITON	2 pcs.
13	9614643001	10112F	GJ PF FT OUTPUT SHAFT	1 pcs.
	9614643201	10113FT	GJ FT POWERFLEX GEARHEAD	1 pcs.
24	9614644801	10132	GJ 10 TEE HOUSING CUP	2 pcs.
27	9614645301	10134	GJ 10 NOZZLE HOUSING CUP	2 pcs.
38	9614647701	10512	GJ PF FT INPUT SHAFT	1 pcs.
39	9614647801	10822FT	GJ PF FT ROTOR SHAFT	1 pcs.
51	9614609301	E841	GJ VIII RS CARBIDE THRST WASH	1 pcs.

How to contact Alfa Laval Tank Equipment:

For further information, please feel free to contact:

Alfa Laval Tank Equipment

604 Jeffers Circle, Exton, PA 19341 USA

Tel switchboard: +01 610 408 9940 – Fax switchboard: +01 610 408 9945

www.gamajet.com, www.alfalaval.com, customer service: exton@alfalaval.com

contact details for all countries are continually updated on our websites.

© Alfa Laval Corporate AB

This document and its contents is owned by Alfa Laval Corporate AB and protected by laws governing intellectual property and thereto related rights. It is the responsibility of the user of this document to comply with all applicable intellectual property laws. Without limiting any rights related to this document, no part of this document may be copied, reproduced or transmitted in any form or by any means (electronic, mechanical, photocopying, recording, or otherwise), or for any purpose, without the expressed permission of Alfa Laval Corporate AB. Alfa Laval Corporate AB will enforce its rights related to this document to the fullest extent of the law, including the seeking of criminal prosecution.